



BRICK SLIPS
 BRICKS
 ACROBRIC
 TILES
 PAVING STONES
 SCREEN WALLS

2024

PRODUCT **CATALOGUE**

FROM JANUAR 1ST, 2024

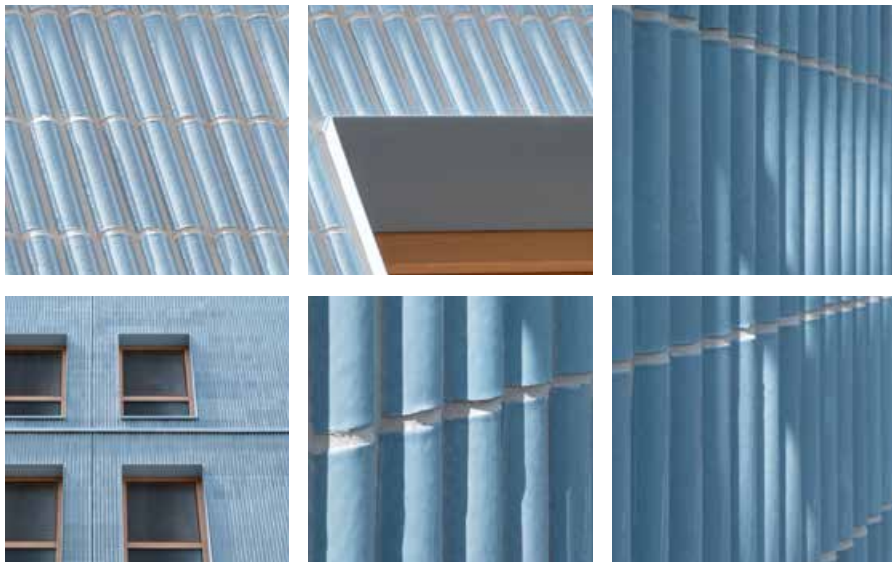

Rairies
 Montrieux
 TERRE D'ORIGINE



CONTENT



COMPANY PRESENTATION	
RAIRIES MONTRIEUX	P 4
Sales department	P 6
Orders	P 7
Logistics	P 8
Research & Development Department	P 9
Specifications and technical advice	P 10
Thermal insulation	P 11

RAIRIES MONTRIEUX PRODUCTS	
Brick slips	P 13
Coste profile	P 37
Bricks	P 39
Acrobic	P 59
Tiles	P 63
Paving stones	P 67
Screen walls	P 69
General Sales Terms and Conditions	P 71

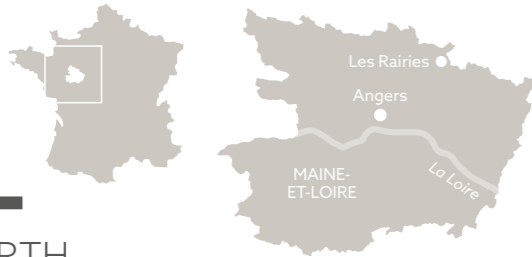

EARTH WITH PASSION AND RESPECT.

We work with passion and we love our work because we know the terracotta industry is eco-friendly. Plentiful and renewable, the extraction of clay needs no water, no explosives and no chemicals. Besides, our nearby quarries allow shorter transportation. With a sustainability exceeding 100 years, we understand why these factors, all put together, give terracotta such a good carbon footprint and make it one of tomorrow's top building materials.



TERRACOTTA A FORERUNNER IN SUSTAINABILITY.

Thanks to our clay extraction process and brick craftwork, terracotta is a model in terms of sustainable development. On that ground, it already complies with the 2018 French Energy Transition Law stating the requirements in terms of energy performance, low environmental impact and decrease of greenhouse gas emissions.



FDES
Natural terracotta
and Engobed



FDES
Wood kiln fired



FDES
Two-fired glazing

A UNIQUE, RECOGNIZED KNOW-HOW CONSTANTLY ENRICHED BY CRAFTSMANSHIP.

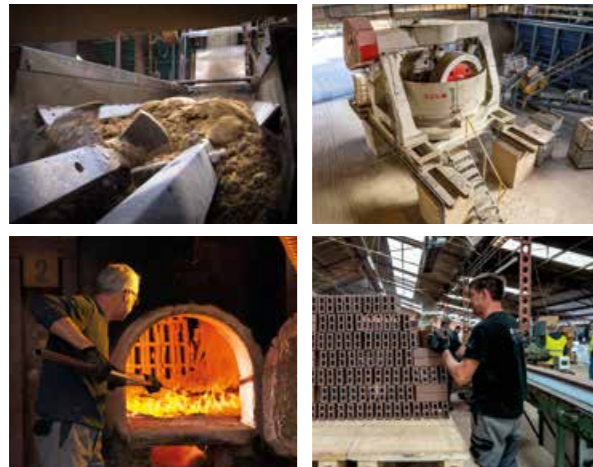

Our know-how has also been recognised with the "ENTREPRISE DU PATRIMOINE VIVANT" label. The award acknowledges "economic heritage" and "exceptional, renowned or ancestral know-how. Know-how grounded in expertise in traditional or highly complex techniques synonymous with a given region."

RAIRIES MONTRIEUX was awarded the "PRODUIT EN ANJOU" label, a local hallmark of quality. Goods must be produced in Anjou, with its constituent parts originating or having been produced in the Maine et Loire region.



RAIRIES MONTRIEUX 2 SHOWROOMS TO ACCOMPANY YOUR PROJECTS.

You would like a presentation of our products and know-how, or discuss a specific project? Come and visit our showroom in Paris located at the Viaduc des Arts. There you can see and feel our products and immerse in the heart of our expertise. We happily welcome you at "Les Rairies", where our second showroom is located directly at our production site.

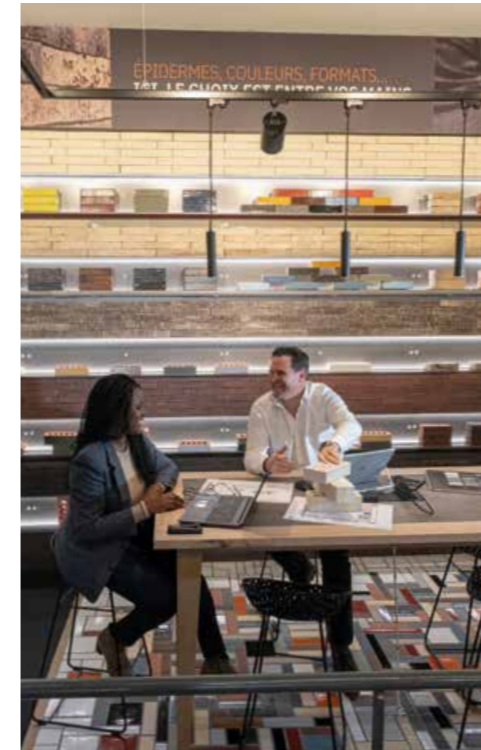

To meet your highest standards of excellence, we are committed to:

- Assisting you at finding solutions adapted to your building projects (new constructions, renovation...),
- Advising you on how to use our products,
- Continually improving our policy by implementing the new regulations in force,
- Listening to your needs and meeting the requirements at all stages of your project.

SHOWROOM PARIS
113 avenue Daumesnil
75012 Paris
Tel: +33(0)1 53 02 49 00
p.benaiche@montrieux.fr

SHOWROOM LES RAIRIES
1 rue des Fourneaux
49430 Les Rairies
Tel: +33(0)2 41 21 15 20
contact@montrieux.fr



AT YOUR SERVICE

WE RESPOND TO ARCHITECTURAL PROJECTS ALL AROUND THE WORLD.

YOU NEED ASSISTANCE OR HAVE A QUESTION?
DO NOT HESITATE TO CONTACT OUR EXPORT TEAM.



Paul-Vincent DIQUERO
Export Sales Director
+33 (0)6 27 13 65 19
pv.diquero@montrieux.fr



Elisabeth JAMELOT
Export Sales Assistant
+33(0)2 41 21 15 25
e.jamelot@montrieux.fr



Léa DODIER
Export Sales Apprentice
l.dodier@montrieux.fr



OUR WEBSITE

Please visit our website for any information on our products.
Technical data sheets can be downloaded directly for each product.

www.rairies.com



YOUR ORDERS



Please transmit your orders per e-mail on corporate letterhead with your contact details.

Orders are registered by our Sales Department. The order confirmation is then created and sent to the customer with the following information:

- ✓ Client ID
- ✓ Delivery Address
- ✓ Client's order reference (N° and/or name of the project)
- ✓ Date of the order
- ✓ Internal order n°
- ✓ Product reference, quantity and price
- ✓ Estimated date of dispatch and/or lead time
- ✓ Transport costs if applicable

The confirmation of order shall be returned to our Sales Department duly signed and dated, preceded by the expression "accepted and agreed".

Should the products be available, please confirm your needs in terms of transport agreement as well as the type of equipment necessary to unload the products. Do not hesitate to specify a delivery schedule, if requested.

Lead times and delivery dates start from the validation of the order confirmation by your company.

All confirmation of order implies the agreement without any reserve of our General Sales Terms & Conditions, retention of title and price list.

In case an order is modified, the initial internal order n° of the confirmation must be indicated. Any modification may change the availability date of the products.

In case you notice a difference between your order and the confirmation of order registered by our Sales Department, please contact us or send us the modifications by email. Otherwise any subsequent complaint related to the order confirmation shall not be taken into account.

Any complaint related to a quality issue shall be sent to the export sales director by stating the reference of the delivery note and product.

Any other type of complaint (price, reference...) shall be sent to our Sales Department. In accordance with our General Sales Terms & Conditions, any complaint sent beyond a period of 48hrs after the delivery of products shall not be considered.

For any further information, please contact our Sales Department



Sabrina PETIT
Sales Administrator
(orders and samples)
+33 (0)2 41 21 15 23
s.petit@montrieux.fr



LOGISTICS

CHOOSING THE BEST SOLUTION FOR YOUR PROJECT.

Our standard practice is to supply using the FCA incoterm. This means we provide the packaged goods, load the pallets onto the means of transport chosen by the customer and handle the export customs declaration via our broker.

If you wish to receive your orders transport included, we are happy to provide a quotation, based on the location of delivery.

Rairies Montrieux has implemented logistical partnerships to meet your needs and optimize delivery lead times and costs.

Do not hesitate to contact our export sales team for any further information.

Anticipate the delivery requirements to make sure you receive the goods at the best possible price and lead times.

For the delivery of your order, the following details have to be communicated:

- ✓ Date of requested delivery,
- ✓ Detailed delivery address,
- ✓ Name of contact person on site of delivery,
- ✓ Equipment necessary for unloading the products.

In case of successive deliveries, please send a delivery timeline upon order, so as to schedule the production accordingly and organize the deliveries with best possible lead times.



Antoine CHENNEBAULT
Logistics Manager
+33 (0) 2 41 21 15 22
logistique@montrieux.fr



RESEARCH & DEVELOPMENT DEPARTMENT

Together, let's reveal your creative mind

At Rairies-Montrieux, we believe that a successful project is based first and foremost on active listening, sharing and constant support.

Our team of ceramics engineers uses their expertise to support architects, project managers, building authorities, and professionals of the construction sector with their specific projects.

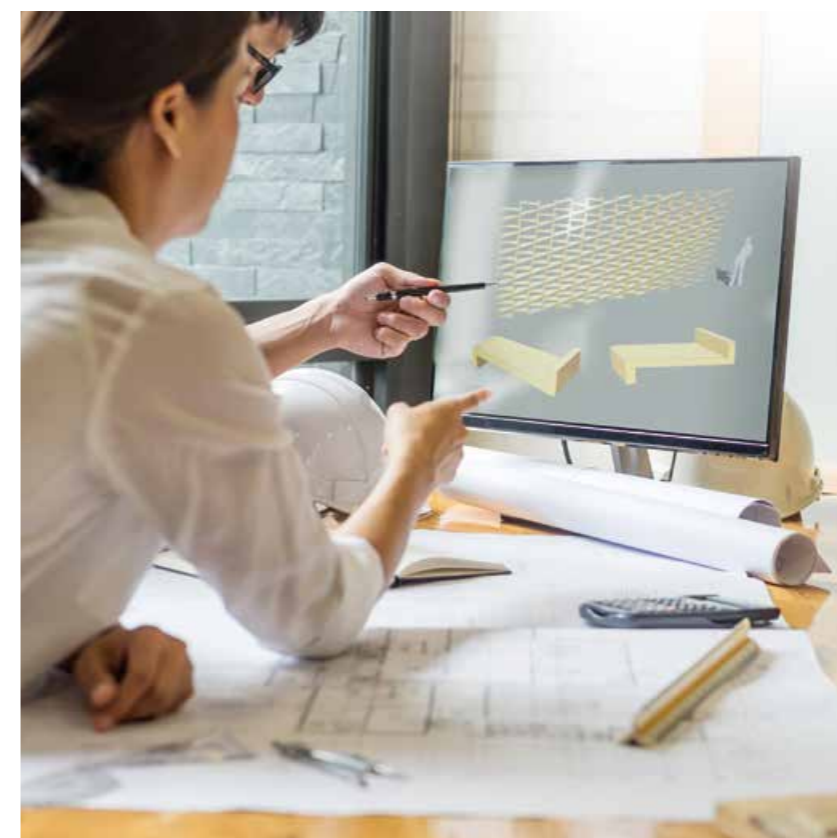

Shapes, colours... we take into account all your requirements to meet the uniqueness of your project.

We listen to you, understand you, and give you our recommendations ...

While working on your project, we constantly focus on its unicity. From the selection of shades to shapes, our research and development department examines thoroughly all its characteristics down to the details. After having carefully analysed all these parameters, we provide you with the best technical solutions.

All our products are CE marked.



Arnaud CHEVET
Factory Director
+33 (0)2 41 21 15 37
a.chevet@montrieux.fr



Olivier LAVAL
Technical Director
+33 (0)6 41 94 62 53
o.laval@montrieux.fr

SPECIFICATIONS AND TECHNICAL ADVICE

Realisation of your projects

All our terracotta products can be used for external insulation solutions and installed on:

- Insulating frame for brick slips,
- insulating wall panel,
- cladding panel,
- detachable insulating wall panel,
- or as detachable cladding system for ACROBRIC products,
- cladding on wooden or metallic frames,
- cavity walls for any brick models.

You can find and download the technical data sheets and DOPs in the product section of our website www.rairies.com



Any question on how to use and install our products on the building site? Our technical team is here for advice and support.

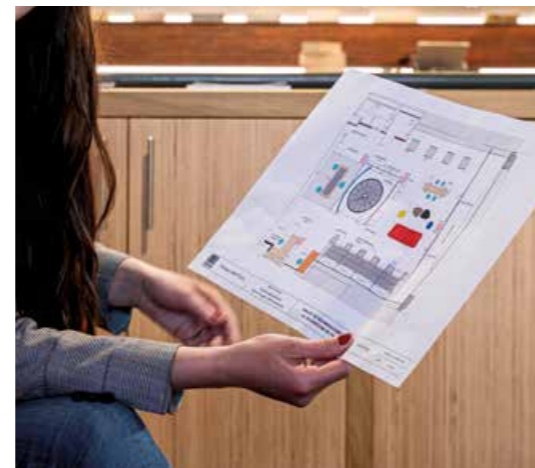

CHARACTERISTICS

The quantities per sqm can vary depending on the width of the joint and are therefore only indicated as guidance.

Shades are given for information only and can slightly vary from one production cycle to another. To ensure the homogeneity of our products, we recommend to order the exact quantities needed for the entire project, so that all products come from the same batch.

We also recommend that the pallets and products are homogeneously mixed during the installation process as to obtain a well-balanced layout.

Quantities per pallet are given as estimation only and can vary according to production constraints.

We reserve the right to modify or cancel products whenever necessary.

Our products comply with all French construction STANDARDS and UTD in force.

THERMAL INSULATION



OUR CLADDING SOLUTIONS

ARE COMPATIBLE WITH EXTERNAL THERMAL INSULATION.

Detachables insulating slip wall panel glued on liner

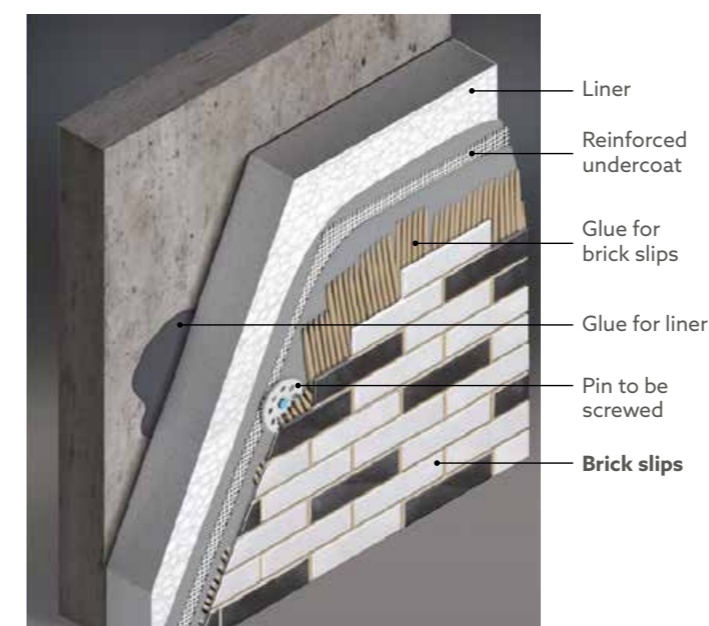

References in compliance with the use of fixing with adhesives on liner. Solar absorption coefficient <math>< 0.70</math>. Thermal expansion upon contact with boiling water <math>< 0.3 \text{ mm/m}</math>

Compatible with the following manufacturer systems:



Colours and Products available for detachable insulating wall panel systems: a large choice of shades with low solar absorption

To bring all your projects to life, RAIRIES MONTRIEUX provides new technical solutions to meet architectural requirements and offers a range of 80 shades from light to dark! This wide array of shades, has been developed by our R & D department, to reflect infrared radiation and provide solar absorption coefficients below 0.70.

α = solar absorption coefficient

COLOURED GLAZING

Gris 3 α 0,62	Gris 4 α 0,51	Gris 5 α 0,35	Vanille α 0,51	Chatain α 0,55
Cacao α 0,69	Bleu 1 α 0,67	Bleu 2 α 0,60	Bleu 3 α 0,67	Jaune α 0,46
Orange α 0,50	Rouge 1 α 0,57	Rouge 2 α 0,47	Rouge 3 α 0,67	Rouge 4 α 0,47
Aubergine 1 α 0,68	Vert 2 α 0,64	Vert 4 α 0,62	Vert 5 α 0,70	Beige 1 α 0,33
Blanc Mat α 0,38	Blanc Brillant α 0,39			

METAL GLAZING

Cuivre α 0,56	Or α 0,70	Doré α 0,40	Argenté α 0,39	Irisé α 0,31

CRYSTAL-CLEAR GLAZING

PLAIN OR SHADED

Flanelle α 0,55	Cosmos α 0,68	Oxygène α 0,56	Sable α 0,47	Frêne α 0,50
Merisier α 0,56	Chêne α 0,58	Laurier α 0,55	Eucalyptus α 0,59	Lagon α 0,66
Noyer α 0,63	Vert d'eau α 0,61	Nénuphar α 0,69	Coquelicot α 0,49	

SINGLE-FIRED GLAZING

Blanc Brillant α 0,33	Blanc Mat α 0,31	Blanc Satiné α 0,24	Gris 2 α 0,66	Gris 3 α 0,56	Gris 4 α 0,51
Gris 5 α 0,45	MonoRouge 1 α 0,57	MonoVert 5 α 0,65	MonoVert 6 α 0,70	MonoBleu 3 α 0,65	MonoJaune α 0,49

ENGOBED COLOURED TERRACOTTA

MontBlanc17 α 0,15	MontBlanc Mat α 0,24	MontGris 1 α 0,69	MontGris 2 α 0,70	MontGris 3 α 0,67	MontGris 4 α 0,59
MontGris 5 α 0,39	MontGris 6 α 0,41	MontBleu 8 α 0,68	MontBleu 9 α 0,47	MontVert α 0,55	MontBrun α 0,64
MontBeige α 0,34	MontBeige 1 α 0,35	MontBeige 2 α 0,41	MontJaune α 0,31	MontRose α 0,38	

NATURAL TERRACOTTA

Lumière α 0,30	Antarès α 0,36	Silver α 0,46	Titane α 0,51	Havane α 0,55
Montlouis α 0,46	Montvaloir α 0,51	Médoc α 0,57	Étain α 0,38	

TRANSPARENT GLAZING

Lumière α 0,28	Antarès α 0,46	Silver α 0,56	Titane α 0,62	Havane α 0,67
Montlouis α 0,55	Montvaloir α 0,64	Médoc α 0,67		

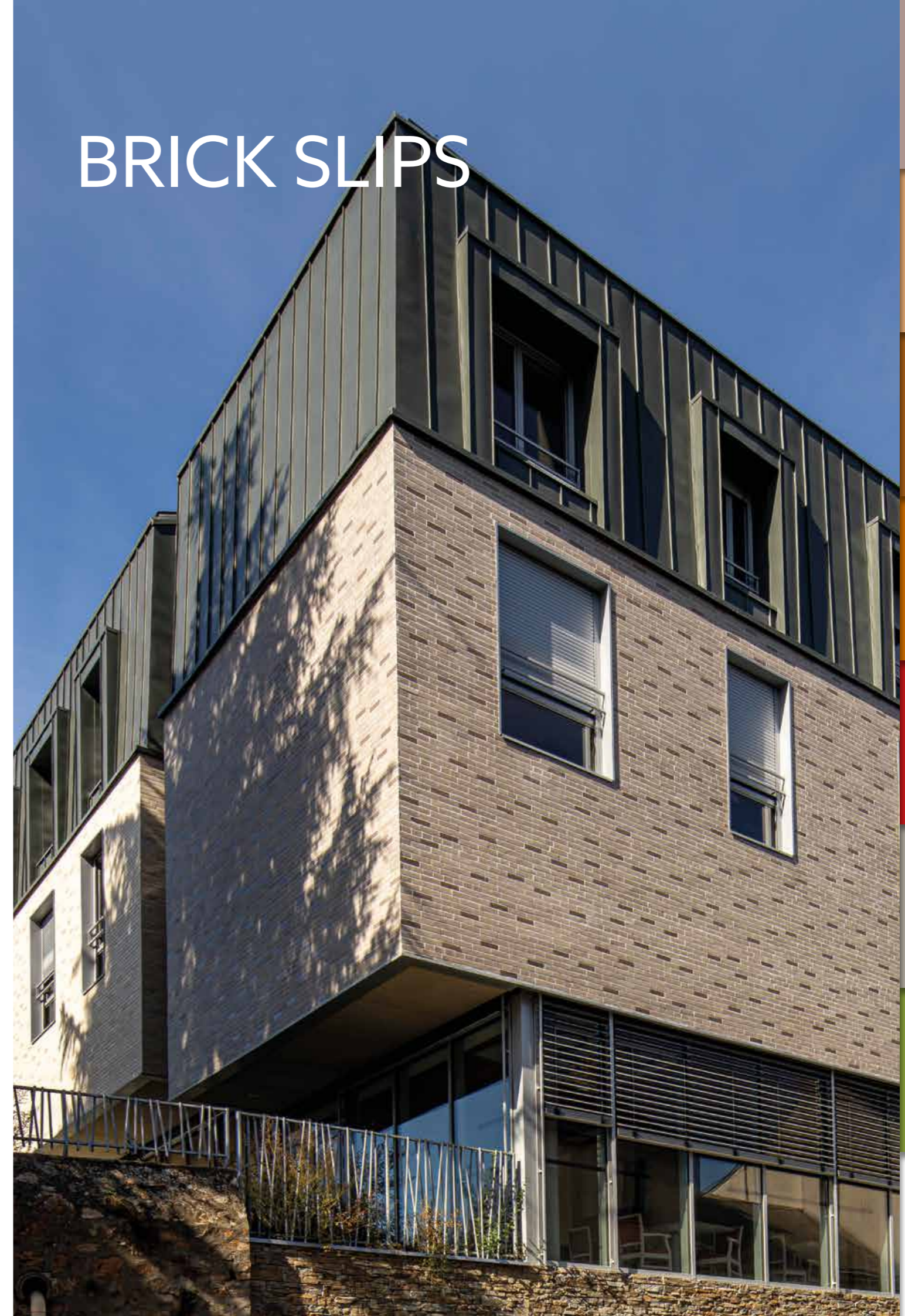

BRICK SLIPS

BRICKS SLIPS

COSIE PROFILE

BRICKS

ACROBRIC

TILES

PAVING STONES

SCREEN WALLS

GENERAL SALESTERMS AND CONDITIONS



TYPES OF BRICK SLIPS

Straight

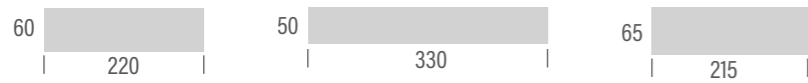

Corner

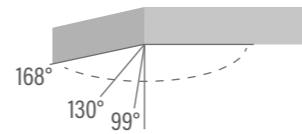
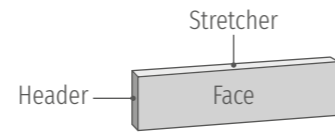
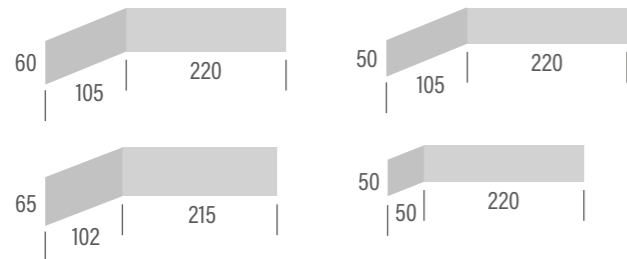

We propose corner bricks slips of 99°, 130°, 168°. For any other obtuse CORNER, **please contact us!**

BONDING PATTERNS WITH CORNER BRICK SLIPS

220 x 60 x 12 mm cross bond 1/2

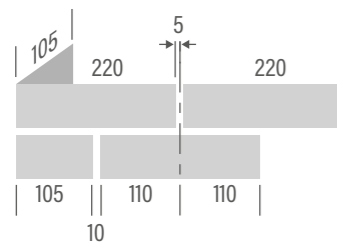

330 x 50 x 12 mm cross bond 1/3

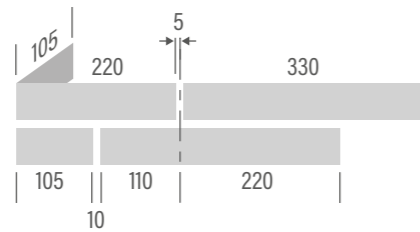

330 x 50 x 12 mm cross bond 1/2

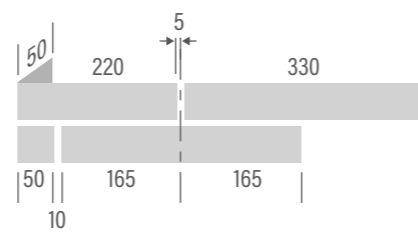

215 x 65 x 12 mm cross bond 1/2

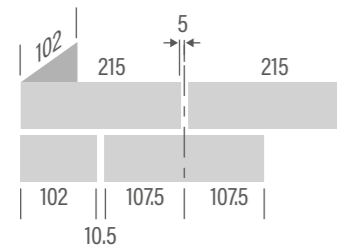

NATURAL TERRACOTTA - SMOOTH



REFERENCE	PRODUCT DESIGNATION	FORMAT L x w x H in mm	QUANTITY sqm or lm	WEIGHT sqm or unit	INDICATIVE QUANTITY		WEIGHT in kg/pallet	SALES UNIT
					sqm/box or u/box	sqm/pallet or u/pallet		
BRICK SLIPS - 12 MM THICKNESS								
FAP20DL226012-Code	60 mm STRAIGHT	220 x 60 x 12	62/sqm	18 kg	0,97 sqm	48,4 sqm	880 kg	sqm
FAP20AL2216012-Code	60 mm CORNER	220 x 105 x 60 x 12	14,3/lm	0,44 kg	50 u	2 100 u	902 kg	unit
FAP20DL335012-Code	50 mm STRAIGHT	330 x 50 x 12	50/sqm	18 kg	0,96 sqm	48 sqm	875 kg	sqm
FAP20AL2215012-Code	50 mm CORNER	220 x 105 x 50 x 12	16,7/lm	0,36 kg	50 u	2 400 u	864 kg	unit
FAP20AL2255012-Code	50 mm CORNER	220 x 50 x 50 x 12	16,7/lm	0,32 kg	50 u	2 700 u	864 kg	unit
FAP20DL216512-Code	65 mm STRAIGHT	215 x 65 x 12	59/sqm	18 kg	1,02 sqm	50,8 sqm	925 kg	sqm
FAP20AL2116512-Code	65 mm CORNER	215 x 102 x 65 x 12	13,3/lm	0,46 kg	50 u	2 100 u	976 kg	unit
FAP20AV2266012-Code	VERTICAL CORNER	220 x 60 x 60 x 12	4,3/lm	0,50 kg	24 u	1 890 u	945 kg	unit
FAP20AV3355012-Code	VERTICAL CORNER	330 x 50 x 50 x 12	3/lm	CU	CU	CU	CU	unit
	VERTICAL CORNER	Other formats are available within the limit of 330 x 60 x 60 x 12 or 220 x 105 x 105 x 12						

FAP20XC225012-Code	CONVEX CURVE Radius 1020 mm	220 x 50 x 12	72/sqm	18 kg	CU	CU	CU	unit
FAP20XC226012-Code	CONVEX CURVE Radius 1020 mm	220 x 60 x 12	62/sqm	18 kg	CU	CU	CU	unit
	CONVEX CURVE	Other formats are available for a radius between 160 mm & 2800 mm						

BRICK SLIPS - 15 MM THICKNESS								
FAP20DL226515-Code	65 mm STRAIGHT	220 x 65 x 15	58/sqm	22,5 kg	0,83 sqm	41,4 sqm	931 kg	sqm
FAP20AL2216515-Code	65 mm CORNER	220 x 105 x 65 x 15	13,3/lm	0,55 kg	40 u	1 680 u	924 kg	unit
FAP20DL335015-Code	50 mm STRAIGHT	330 x 50 x 15	50/sqm	22,5 kg	0,72 sqm	36 sqm	820 kg	sqm
FAP20DL455015-Code	50 mm STRAIGHT	450 x 50 x 15	36/sqm	22,5 kg	0,5 sqm	40 sqm	900 kg	sqm
FAP20AL2215015-Code	50 mm CORNER	220 x 105 x 50 x 15	16,7/lm	0,45 kg	40 u	1 920 u	864 kg	unit
FAP20AL2255015-Code	50 mm CORNER	220 x 50 x 50 x 15	16,7/lm	0,4 kg	40 u	2 160 u	864 kg	unit

BRICK SLIPS - 20/25 MM THICKNESS								
FAP20DL226020-Code	60 mm STRAIGHT	220 x 60 x 20	62/sqm	30 kg	0,58 sqm	29 sqm	880 kg	sqm
FAP20AL2216020-Code	60 mm CORNER	220 x 105 x 60 x 20	14,3/lm	0,73 kg	30 u	1 260 u	920 kg	unit
FAP20DL226025-Code	60 mm STRAIGHT	220 x 60 x 25	62/sqm	37,5 kg	0,45 sqm	22,6 sqm	857 kg	sqm
FAP20AL2216025-Code	60 mm CORNER	220 x 105 x 60 x 25	14,3/lm	0,9125 kg	24 u	1 008 u	920 kg	unit
FAP20DL335020-Code	50 mm STRAIGHT	330 x 50 x 20	50/sqm	30 kg	0,6 sqm	30 sqm	910 kg	sqm
FAP20AL2215020-Code	50 mm CORNER	220 x 105 x 50 x 20	16,7/lm	0,6 kg	30 u	1 440 u	864 kg	unit
FAP20DL335025-Code	50 mm STRAIGHT	330 x 50 x 25	50/sqm	37,5 kg	0,48 sqm	24 sqm	910 kg	sqm
FAP20AL2215025-Code	50 mm CORNER	220 x 105 x 50 x 25	16,7/lm	0,75 kg	24 u	1 152 u	864 kg	unit

CU = Contact Us - * Sqm = with 10 mm joint

Pallet 80 x 120 cm



103 Lumière - α 0,30



109 Silver - α 0,46



110 Titane - α 0,51



116 Étain - α 0,38



102 Havane - α 0,55



108 Réglisse - α 0,78



101 Antarès - α 0,36



105 Montlouis - α 0,46



106 Montvaloir - α 0,51



104 Médoc - α 0,57

α = solar absorption coefficient

NATURAL TERRACOTTA - COLISEE

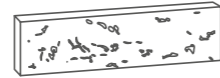

REFERENCE	PRODUCT DESIGNATION	FORMAT L x w x H in mm	QUANTITY sqm or lm	WEIGHT sqm or unit	INDICATIVE QUANTITY		WEIGHT in kg/pallet	SALES UNIT
					sqm/box or u/box	sqm/pallet or u/pallet		
BRICK SLIPS - 12 MM THICKNESS								
FAP20DC226012-Code	60 mm STRAIGHT	220 x 60 x 12	62/sqm	18 kg	0,97 sqm	48,4 sqm	880 kg	sqm
FAP20AC2216012-Code	60 mm CORNER	220 x 105 x 60 x 12	14,3/lm	0,44 kg	50 u	2 100 u	902 kg	unit
FAP20DC335012-Code	50 mm STRAIGHT	330 x 50 x 12	50/sqm	18 kg	0,96 sqm	48 sqm	875 kg	sqm
FAP20AC2215012-Code	50 mm CORNER	220 x 105 x 50 x 12	16,7/lm	0,36 kg	50 u	2 400 u	864 kg	unit
FAP20AC2255012-Code	50 mm CORNER	220 x 50 x 50 x 12	16,7/lm	0,32 kg	50 u	2 700 u	864 kg	unit
FAP20DC216512-Code	65 mm STRAIGHT	215 x 65 x 12	59/sqm	18 kg	1,02 sqm	50,8 sqm	925 kg	sqm
FAP20AC2116512-Code	65 mm CORNER	215 x 102 x 65 x 12	13,3/lm	0,46 kg	50 u	2 100 u	976 kg	unit
FAP20AV-----CODE	VERTICAL CORNER	220 x 60 x 60 x 12	4,3/lm	0,50 kg	24 u	1 890 u	945 kg	unit
FAP20AV-----CODE	VERTICAL CORNER	330 x 50 x 50 x 12	3/lm	CU	CU	CU	CU	unit
	VERTICAL CORNER	Other formats are available within the limit of 330 x 60 x 60 x 12 or 220 x 105 x 105 x 12						

BRICK SLIPS - 15 MM THICKNESS								
FAP20DC226515-Code	65 mm STRAIGHT	220 x 65 x 15	58/sqm	22,5 kg	0,83 sqm	41,4 sqm	931 kg	sqm
FAP20AC2216515-Code	65 mm CORNER	220 x 105 x 65 x 15	13,3/lm	0,55 kg	40 u	1 680 u	924 kg	unit
FAP20DC335015-Code	50 mm STRAIGHT	330 x 50 x 15	50/sqm	22,5 kg	0,72 sqm	36 sqm	820 kg	sqm
FAP20DC455015-Code	50 mm STRAIGHT	450 x 50 x 15	36/sqm	22,5 kg	0,5 sqm	40 sqm	900 kg	sqm
FAP20AC2215015-Code	50 mm CORNER	220 x 105 x 50 x 15	16,7/lm	0,45 kg	40 u	1 920 u	864 kg	unit
FAP20AC2255015-Code	50 mm CORNER	220 x 50 x 50 x 15	16,7/lm	0,4 kg	40 u	2 160 u	864 kg	unit

BRICK SLIPS - 20/25 MM THICKNESS								
FAP20DC226020-Code	60 mm STRAIGHT	220 x 60 x 20	62/sqm	30 kg	0,58 sqm	29 sqm	880 kg	sqm
FAP20AC2216020-Code	60 mm CORNER	220 x 105 x 60 x 20	14,3/lm	0,73 kg	30 u	1 260 u	920 kg	unit
FAP20DC226025-Code	60 mm STRAIGHT	220 x 60 x 25	62/sqm	37,5 kg	0,45 sqm	22,6 sqm	857 kg	sqm
FAP20AC2216025-Code	60 mm CORNER	220 x 105 x 60 x 25	14,3/lm	0,9125 kg	24 u	1 008 u	920 kg	unit
FAP20DC335020-Code	50 mm STRAIGHT	330 x 50 x 20	50/sqm	30 kg	0,6 sqm	30 sqm	910 kg	sqm
FAP20AC2215020-Code	50 mm CORNER	220 x 105 x 50 x 20	16,7/lm	0,6 kg	30 u	1 440 u	864 kg	unit
FAP20DC335025-Code	50 mm STRAIGHT	330 x 50 x 25	50/sqm	37,5 kg	0,48 sqm	24 sqm	910 kg	sqm
FAP20AC2215025-Code	50 mm CORNER	220 x 105 x 50 x 25	16,7/lm	0,75 kg	24 u	1 230 u	922 kg	unit

CU = Contact Us - * Sqm = with 10 mm joint

Pallet 80 x 120 cm



103 Lumière - α 0,30



102 Havane - α 0,55



105 Montlouis - α 0,46



109 Silver - α 0,46



108 Réglisse - α 0,78



106 Montvaloir - α 0,51



110 Titane - α 0,51



101 Antarès - α 0,36

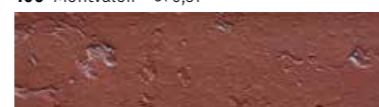

104 Médoc - α 0,57



116 Étain - α 0,38

α = solar absorption coefficient

NATURAL TERRACOTTA - DRAGWIRE



REFERENCE	PRODUCT DESIGNATION	FORMAT L x w x H in mm	QUANTITY sqm or lm	WEIGHT sqm or unit	INDICATIVE QUANTITY		WEIGHT in kg/pallet	SALES UNIT
					sqm/box or u/box	sqm/pallet or u/pallet		
BRICK SLIPS - 12 MM THICKNESS								
FAP20DA226012-Code	60 mm STRAIGHT	220 x 60 x 12	62/sqm	18 kg	0,97 sqm	48,4 sqm	880 kg	sqm
FAP20AA2216012-Code	60 mm CORNER	220 x 105 x 60 x 12	14,3/lm	0,44 kg	50 u	2 100 u	902 kg	unit
FAP20DA335012-Code	50 mm STRAIGHT	330 x 50 x 12	50/sqm	18 kg	0,96 sqm	48 sqm	875 kg	sqm
FAP20AA2215012-Code	50 mm CORNER	220 x 105 x 50 x 12	16,7/lm	0,36 kg	50 u	2 400 u	864 kg	unit
FAP20AA2255012-Code	50 mm CORNER	220 x 50 x 50 x 12	16,7/lm	0,32 kg	50 u	2 700 u	864 kg	unit
FAP20AA216512-Code	65 mm STRAIGHT	215 x 65 x 12	59/sqm	18 kg	1,02 sqm	50,8 sqm	925 kg	sqm
FAP20AA2116512-Code	65 mm CORNER	215 x 102 x 65 x 12	13,3/lm	0,46 kg	50 u	2 100 u	976 kg	unit
FAP20AV-----CODE	VERTICAL CORNER	220 x 60 x 60 x 12	4,3/lm	0,50 kg	24 u	1 890 u	945 kg	unit
FAP20AV-----CODE	VERTICAL CORNER	330 x 50 x 50 x 12	3/lm	CU	CU	CU	CU	unit
	VERTICAL CORNER	Other formats are available within the limit of 330 x 60 x 60 x 12 or 220 x 105 x 105 x 12						

BRICK SLIPS - 15 MM THICKNESS								
FAP20DA226515-Code	65 mm STRAIGHT	220 x 65 x 15	58/sqm	22,5 kg	0,83 sqm	41,4 sqm	931 kg	sqm
FAP20AA2216515-Code	65 mm CORNER	220 x 105 x 65 x 15	13,3/lm	0,55 kg	40 u	1 680 u	924 kg	unit
FAP20DA335015-Code	50 mm STRAIGHT	330 x 50 x 15	50/sqm	22,5 kg	0,72 sqm	36 sqm	820 kg	sqm
FAP20DA455015-Code	50 mm STRAIGHT	450 x 50 x 15	36/sqm	22,5 kg	0,5 sqm	40 sqm	900 kg	sqm
FAP20AA2215015-Code	50 mm CORNER	220 x 105 x 50 x 15	16,7/lm	0,45 kg	40 u	1 920 u	864 kg	unit
FAP20AA2255015-Code	50 mm CORNER	220 x 50 x 50 x 15	16,7/lm	0,4 kg	40 u	2 160 u	864 kg	unit

BRICK SLIPS - 20/25 MM THICKNESS								
FAP20DA226020-Code	60 mm STRAIGHT	220 x 60 x 20	62/sqm	30 kg	0,58 sqm	29 sqm	880 kg	sqm
FAP20AA2216020-Code	60 mm CORNER	220 x 105 x 60 x 20	14,3/lm	0,73 kg	30 u	1 260 u	920 kg	unit
FAP20DA226025-Code	60 mm STRAIGHT	220 x 60 x 25	62/sqm	37,5 kg	0,45 sqm	22,6 sqm	857 kg	sqm
FAP20AA2216025-Code	60 mm CORNER	220 x 105 x 60 x 25	14,3/lm	0,9125 kg	24 u	1 008 u	920 kg	unit
FAP20DA335020-Code	50 mm STRAIGHT	330 x 50 x 20	50/sqm	30 kg	0,6 sqm	30 sqm	910 kg	sqm
FAP20AA2215020-Code	50 mm CORNER	220 x 105 x 50 x 20	16,7/lm	0,6 kg	30 u	1 440 u	864 kg	unit
FAP20DA335025-Code	50 mm STRAIGHT	330 x 50 x 25	50/sqm	37,5 kg	0,48 sqm	24 sqm	910 kg	sqm
FAP20AA2215025-Code	50 mm CORNER	220 x 105 x 50 x 25	16,7/lm	0,75 kg	24 u	1 230 u	922 kg	unit

CU = Contact Us - * Sqm = with 10 mm joint

Pallet 80 x 120 cm



103 Lumière - α 0,30



102 Havane - α 0,55



105 Montlouis - α 0,46



109 Silver - α 0,46



108 Réglisse - α 0,78



106 Montvaloir - α 0,51



110 Titane - α 0,51



101 Antarès - α 0,36



104 Médoc - α 0,57



116 Étain - α 0,38

α = solar absorption coefficient

NATURAL TERRACOTTA - BARK

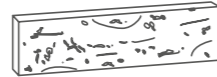

REFERENCE	PRODUCT DESIGNATION	FORMAT L x w x H in mm	QUANTITY sqm or lm	WEIGHT sqm or unit	INDICATIVE QUANTITY		WEIGHT in kg/pallet	SALES UNIT
					sqm/box or u/box	sqm/pallet or u/pallet		
BRICK SLIPS - 12 MM THICKNESS								
FAP20DE226012-Code	60 mm STRAIGHT	220 x 60 x 12	62/sqm	18 kg	0,97 sqm	48,4 sqm	880 kg	sqm
FAP20AE2216012-Code	60 mm CORNER	220 x 105 x 60 x 12	14,3/lm	0,44 kg	50 u	2 100 u	902 kg	unit
FAP20DE335012-Code	50 mm STRAIGHT	330 x 50 x 12	50/sqm	18 kg	0,96 sqm	48 sqm	875 kg	sqm
FAP20AE2215012-Code	50 mm CORNER	220 x 105 x 50 x 12	16,7/lm	0,36 kg	50 u	2 400 u	864 kg	unit
FAP20AE2255012-Code	50 mm CORNER	220 x 50 x 50 x 12	16,7/lm	0,32 kg	50 u	2 700 u	864 kg	unit
FAP20DE216512-Code	65 mm STRAIGHT	215 x 65 x 12	59/sqm	18 kg	1,02 sqm	50,8 sqm	925 kg	sqm
FAP20AE216512-Code	65 mm CORNER	215 x 102 x 65 x 12	13,3/lm	0,46 kg	50 u	2 100 u	976 kg	unit
FAP20AV-----CODE	VERTICAL CORNER	220 x 60 x 60 x 12	4,3/lm	0,50 kg	24 u	1 890 u	945 kg	unit
FAP20AV-----CODE	VERTICAL CORNER	330 x 50 x 50 x 12	3/lm	CU	CU	CU	CU	unit
	VERTICAL CORNER	Other formats are available within the limit of 330 x 60 x 60 x 12 or 220 x 105 x 105 x 12						

BRICK SLIPS - 15 MM THICKNESS								
FAP20DE226515-Code	65 mm STRAIGHT	220 x 65 x 15	58/sqm	22,5 kg	0,83 sqm	41,4 sqm	931 kg	sqm
FAP20AE2216515-Code	65 mm CORNER	220 x 105 x 65 x 15	13,3/lm	0,55 kg	40 u	1 680 u	924 kg	unit
FAP20DE335015-Code	50 mm STRAIGHT	330 x 50 x 15	50/sqm	22,5 kg	0,72 sqm	36 sqm	820 kg	sqm
FAP20DE455015-Code	50 mm STRAIGHT	450 x 50 x 15	36/sqm	22,5 kg	0,5 sqm	40 sqm	900 kg	sqm
FAP20AE2215015-Code	50 mm CORNER	220 x 105 x 50 x 15	16,7/lm	0,45 kg	40 u	1 920 u	864 kg	unit
FAP20AE2255015-Code	50 mm CORNER	220 x 50 x 50 x 15	16,7/lm	0,4 kg	40 u	2 160 u	864 kg	unit

BRICK SLIPS - 20/25 MM THICKNESS								
FAP20DE226020-Code	60 mm STRAIGHT	220 x 60 x 20	62/sqm	30 kg	0,58 sqm	29 sqm	880 kg	sqm
FAP20AE2216020-Code	60 mm CORNER	220 x 105 x 60 x 20	14,3/lm	0,73 kg	30 u	1 260 u	920 kg	unit
FAP20DE226025-Code	60 mm STRAIGHT	220 x 60 x 25	62/sqm	37,5 kg	0,45 sqm	22,6 sqm	857 kg	sqm
FAP20AE2216025-Code	60 mm CORNER	220 x 105 x 60 x 25	14,3/lm	0,9125 kg	24 u	1 008 u	920 kg	unit
FAP20DE335020-Code	50 mm STRAIGHT	330 x 50 x 20	50/sqm	30 kg	0,6 sqm	30 sqm	910 kg	sqm
FAP20AE2215020-Code	50 mm CORNER	220 x 105 x 50 x 20	16,7/lm	0,6 kg	30 u	1 440 u	864 kg	unit
FAP20DE335025-Code	50 mm STRAIGHT	330 x 50 x 25	50/sqm	37,5 kg	0,48 sqm	24 sqm	910 kg	sqm
FAP20AE2215025-Code	50 mm CORNER	220 x 105 x 50 x 25	16,7/lm	0,75 kg	24 u	1 230 u	922 kg	unit

CU = Contact Us - * Sqm = with 10 mm joint

Pallet 80 x 120 cm



103 Lumière - α 0,30



109 Silver - α 0,46

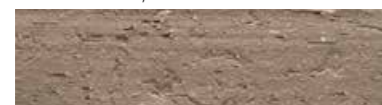

110 Titane - α 0,51

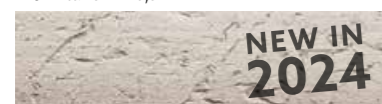

116 Étain - α 0,38



102 Havane - α 0,55



108 Réglisse - α 0,78



101 Antarès - α 0,36



105 Montlouis - α 0,46



106 Montvaloir - α 0,51



104 Médoc - α 0,57

α = solar absorption coefficient

NATURAL TERRACOTTA - SANDY EFFECT

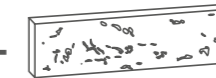

REFERENCE	PRODUCT DESIGNATION	FORMAT L x w x H in mm	QUANTITY sqm or lm	WEIGHT sqm or unit	INDICATIVE QUANTITY		WEIGHT in kg/pallet	SALES UNIT
					sqm/box or u/box	sqm/pallet or u/pallet		
FAP20DG335020-Code	50 mm STRAIGHT	330 x 50 x 20	50/sqm	0,75 kg/u ou 37,5 kg/sqm	0,5 sqm	25 sqm	937,5 kg	sqm

* M² = avec joint de 10 mm



103 Lumière - α 0,30



109 Silver - α 0,46



108 Réglisse - α 0,78



104 Médoc - α 0,57

α = solar absorption coefficient



PRINCIPLE OF BRICK SLIPS GLAZING

STANDARD BRICK SLIP

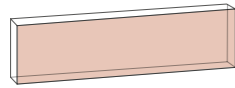

1 side : face

OPTION GLAZING

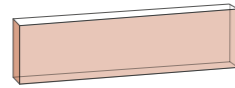

2 sides : face + 1 header

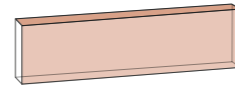

2 sides : face + 1 stretcher

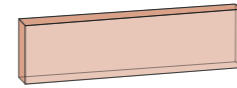

3 sides : face + 1 header + 1 stretcher

ENGOBED, COLOURED TERRACOTTA - SMOOTH



REFERENCE	PRODUCT DESIGNATION	FORMAT L x w x H in mm	QUANTITY sqm or lm	WEIGHT sqm or unit	INDICATIVE QUANTITY		WEIGHT in kg/pallet	SALES UNIT
					sqm/box or u/box	sqm/pallet or u/pallet		
BRICK SLIPS - 12 MM THICKNESS								
FAP22DL226012-Code	60 mm STRAIGHT	220 x 60 x 12	62/sqm	18 kg	0,97 sqm	48,4 sqm	880 kg	sqm
FAP22AL2216012-Code	60 mm CORNER	220 x 105 x 60 x 12	14,3/lm	0,44 kg	50 u	2 100 u	902 kg	unit
FAP22DL335012-Code	50 mm STRAIGHT	330 x 50 x 12	50/sqm	18 kg	0,96 sqm	48 sqm	875 kg	sqm
FAP22AL2215012-Code	50 mm CORNER	220 x 105 x 50 x 12	16,7/lm	0,36 kg	50 u	2 400 u	864 kg	unit
FAP22AL2255012-Code	50 mm CORNER	220 x 50 x 50 x 12	16,7/lm	0,32 kg	50 u	2 700 u	864 kg	unit
FAP22DL216512-Code	65 mm STRAIGHT	215 x 65 x 12	59/sqm	18 kg	1,02 sqm	50,8 sqm	925 kg	sqm
FAP22AL2116512-Code	65 mm CORNER	215 x 102 x 65 x 12	13,3/lm	0,46 kg	50 u	2 100 u	976 kg	unit
FAP22AV2266012-Code	VERTICAL CORNER	220 x 60 x 60 x 12	4,3/lm	0,50 kg	24 u	1 890 u	945 kg	unit
FAP22AV3355012-Code	VERTICAL CORNER	330 x 50 x 50 x 12	3/lm	CU	CU	CU	CU	unit
	VERTICAL CORNER	Other formats are available within the limit of 330 x 60 x 60 x 12 or 220 x 105 x 105 x 12						
FAP22XC225012-Code	CONVEX CURVE Radius 1020 mm	220 x 50 x 12	CU	CU	CU	CU	CU	unit
FAP22XC226012-Code	CONVEX CURVE Radius 1020 mm	220 x 60 x 12	CU	CU	CU	CU	CU	unit
	CONVEX CURVE	Other formats are available for a radius between 160 mm & 2800 mm						
BRICK SLIPS - 15 MM THICKNESS								
FAP22DL226515-Code	65 mm STRAIGHT	220 x 65 x 15	58/sqm	22,5 kg	0,83 sqm	41,4 sqm	931 kg	sqm
FAP22AL2216515-Code	65 mm CORNER	220 x 105 x 65 x 15	13,3/lm	0,55 kg	40 u	1 680 u	924 kg	unit
FAP22DL335015-Code	50 mm STRAIGHT	330 x 50 x 15	50/sqm	22,5 kg	0,72 sqm	36 sqm	820 kg	sqm
FAP22DL455015-Code	50 mm STRAIGHT	450 x 50 x 15	36/sqm	22,5 kg	0,5 sqm	40 sqm	900 kg	sqm
FAP22AL2215015-Code	50 mm CORNER	220 x 105 x 50 x 15	16,7/lm	0,45 kg	40 u	1 920 u	864 kg	unit
FAP22AL2255015-Code	50 mm CORNER	220 x 50 x 50 x 15	16,7/lm	0,4 kg	40 u	2 160 u	864 kg	unit
BRICK SLIPS - 20/25 MM THICKNESS								
FAP22DL226020-Code	60 mm STRAIGHT	220 x 60 x 20	62/sqm	30 kg	0,58 sqm	29 sqm	880 kg	sqm
FAP22AL2216020-Code	60 mm CORNER	220 x 105 x 60 x 20	14,3/lm	0,73 kg	30 u	1 260 u	920 kg	unit
FAP22DL226025-Code	60 mm STRAIGHT	220 x 60 x 25	62/sqm	37,5 kg	0,45 sqm	22,6 sqm	857 kg	sqm
FAP22AL2216025-Code	60 mm CORNER	220 x 105 x 60 x 25	14,3/lm	0,9125 kg	24 u	1 008 u	920 kg	unit
FAP22DL335020-Code	50 mm STRAIGHT	330 x 50 x 20	50/sqm	30 kg	0,6 sqm	30 sqm	910 kg	sqm
FAP22AL2215020-Code	50 mm CORNER	220 x 105 x 50 x 20	16,7/lm	0,6 kg	30 u	1 440 u	864 kg	unit
FAP22DL335025-Code	50 mm STRAIGHT	330 x 50 x 25	50/sqm	37,5 kg	0,48 sqm	24 sqm	910 kg	sqm
FAP22AL2215025-Code	50 mm CORNER	220 x 105 x 50 x 25	16,7/lm	0,75 kg	24 u	1 230 u	922 kg	unit
OPTION GLAZING HEADER AND STRETCHER				0,39 € header / 0,83 € stretcher / 1,12 € header + stretcher				

CU = Contact Us - * Sqm = with 10 mm joint

Pallet 80 x 120 cm



312 MontNoir - α 0,83



307 MontGris 1 - α 0,69



310 MontGris 4 - α 0,59



304 MontBleu 7 - α 0,78



323 MontVert - α 0,55



319 MontBeige - α 0,34



326 MontJaune - α 0,31



302 MontBlanc Mat - α 0,24



308 MontGris 2 - α 0,70



311 MontGris 5 - α 0,39



305 MontBleu 8 - α 0,68



306 MontBrun - α 0,64



324 MontBeige 1 - α 0,35



327 MontRose - α 0,38



301 MontBlanc 17 - α 0,15



309 MontGris 3 - α 0,67



322 MontGris 6 - α 0,41



321 MontBleu 9 - α 0,47



313 MontRouge - α 0,76



325 MontBeige 2 - α 0,41

α = solar absorption coefficient



ENGOBED, COLOURED TERRACOTTA - COLISEE

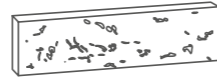

REFERENCE	PRODUCT DESIGNATION	FORMAT L x w x H in mm	QUANTITY sqm or lm	WEIGHT sqm or unit	INDICATIVE QUANTITY		WEIGHT in kg/pallet	SALES UNIT
					sqm/box or u/box	sqm/pallet or u/pallet		
BRICK SLIPS - 12 MM THICKNESS								
FAP22DC226012-Code	60 mm STRAIGHT	220 x 60 x 12	62/sqm	18 kg	0,97 sqm	48,4 sqm	880 kg	sqm
FAP22AC2216012-Code	60 mm CORNER	220 x 105 x 60 x 12	14,3/lm	0,44 kg	50 u	2 100 u	902 kg	unit
FAP22DC335012-Code	50 mm STRAIGHT	330 x 50 x 12	50/sqm	18 kg	0,96 sqm	48 sqm	875 kg	sqm
FAP22AC2215012-Code	50 mm CORNER	220 x 105 x 50 x 12	16,7/lm	0,36 kg	50 u	2 400 u	864 kg	unit
FAP22AC2255012-Code	50 mm CORNER	220 x 50 x 50 x 12	16,7/lm	0,32 kg	50 u	2 700 u	864 kg	unit
FAP22DC2216512-Code	65 mm STRAIGHT	215 x 65 x 12	59/sqm	18 kg	1,02 sqm	50,8 sqm	925 kg	sqm
FAP22AC2216512-Code	65 mm CORNER	215 x 102 x 65 x 12	13,3/lm	0,46 kg	50 u	2 100 u	976 kg	unit
FAP22AV2266012-Code	VERTICAL CORNER	220 x 60 x 60 x 12	4,3/lm	0,50 kg	24 u	1 890 u	945 kg	unit
FAP22AV3355012-Code	VERTICAL CORNER	330 x 50 x 50 x 12	3/lm	CU	CU	CU	CU	unit
	VERTICAL CORNER	Other formats are available within the limit of 330 x 60 x 60 x 12 or 220 x 105 x 105 x 12						
BRICK SLIPS - 15 MM THICKNESS								
FAP22DC226515-Code	65 mm STRAIGHT	220 x 65 x 15	58/sqm	22,5 kg	0,83 sqm	41,4 sqm	931 kg	sqm
FAP22AC2216515-Code	65 mm CORNER	220 x 105 x 65 x 15	13,3/lm	0,55 kg	40 u	1 680 u	924 kg	unit
FAP22DC335015-Code	50 mm STRAIGHT	330 x 50 x 15	50/sqm	22,5 kg	0,72 sqm	36 sqm	820 kg	sqm
FAP22DC455015-Code	50 mm STRAIGHT	450 x 50 x 15	36/sqm	22,5 kg	0,5 sqm	40 sqm	900 kg	sqm
FAP22AC2215015-Code	50 mm CORNER	220 x 105 x 50 x 15	16,7/lm	0,45 kg	40 u	1 920 u	864 kg	unit
FAP22AC2255015-Code	50 mm CORNER	220 x 50 x 50 x 15	16,7/lm	0,4 kg	40 u	2 160 u	864 kg	unit
BRICK SLIPS - 20/25 MM THICKNESS								
FAP22DC226020-Code	60 mm STRAIGHT	220 x 60 x 20	62/sqm	30 kg	0,58 sqm	29 sqm	880 kg	sqm
FAP22AC2216020-Code	60 mm CORNER	220 x 105 x 60 x 20	14,3/lm	0,73 kg	30 u	1 260 u	920 kg	unit
FAP22DC226025-Code	60 mm STRAIGHT	220 x 60 x 25	62/sqm	37,5 kg	0,45 sqm	22,6 sqm	857 kg	sqm
FAP22AC2216025-Code	60 mm CORNER	220 x 105 x 60 x 25	14,3/lm	0,9125 kg	24 u	1 008 u	920 kg	unit
FAP22DC335020-Code	50 mm STRAIGHT	330 x 50 x 20	50/sqm	30 kg	0,6 sqm	30 sqm	910 kg	sqm
FAP22AC2215020-Code	50 mm CORNER	220 x 105 x 50 x 20	16,7/lm	0,6 kg	30 u	1 440 u	864 kg	unit
FAP22DC335025-Code	50 mm STRAIGHT	330 x 50 x 25	50/sqm	37,5 kg	0,48 sqm	24 sqm	910 kg	sqm
FAP22AC2215025-Code	50 mm CORNER	220 x 105 x 50 x 25	16,7/lm	0,75 kg	24 u	1 230 u	922 kg	unit
OPTION GLAZING HEADER AND STRETCHER					0,39 € header / 0,83 € stretcher / 1,12 € header + stretcher			

CU = Contact Us - * Sqm = with 10 mm joint

Pallet 80 x 120 cm



312 MontNoir - α 0,83



302 MontBlanc Mat - α 0,24



301 MontBlanc 17 - α 0,15



307 MontGris 1 - α 0,69



308 MontGris 2 - α 0,70



309 MontGris 3 - α 0,67



310 MontGris 4 - α 0,59



311 MontGris 5 - α 0,39



322 MontGris 6 - α 0,41



304 MontBleu 7 - α 0,78



305 MontBleu 8 - α 0,68



321 MontBleu 9 - α 0,47



323 MontVert - α 0,55



306 MontBrun - α 0,64



313 MontRouge - α 0,76



319 MontBeige - α 0,34



324 MontBeige 1 - α 0,35



325 MontBeige 2 - α 0,41



326 MontJaune - α 0,31



327 MontRose - α 0,38

α = solar absorption coefficient

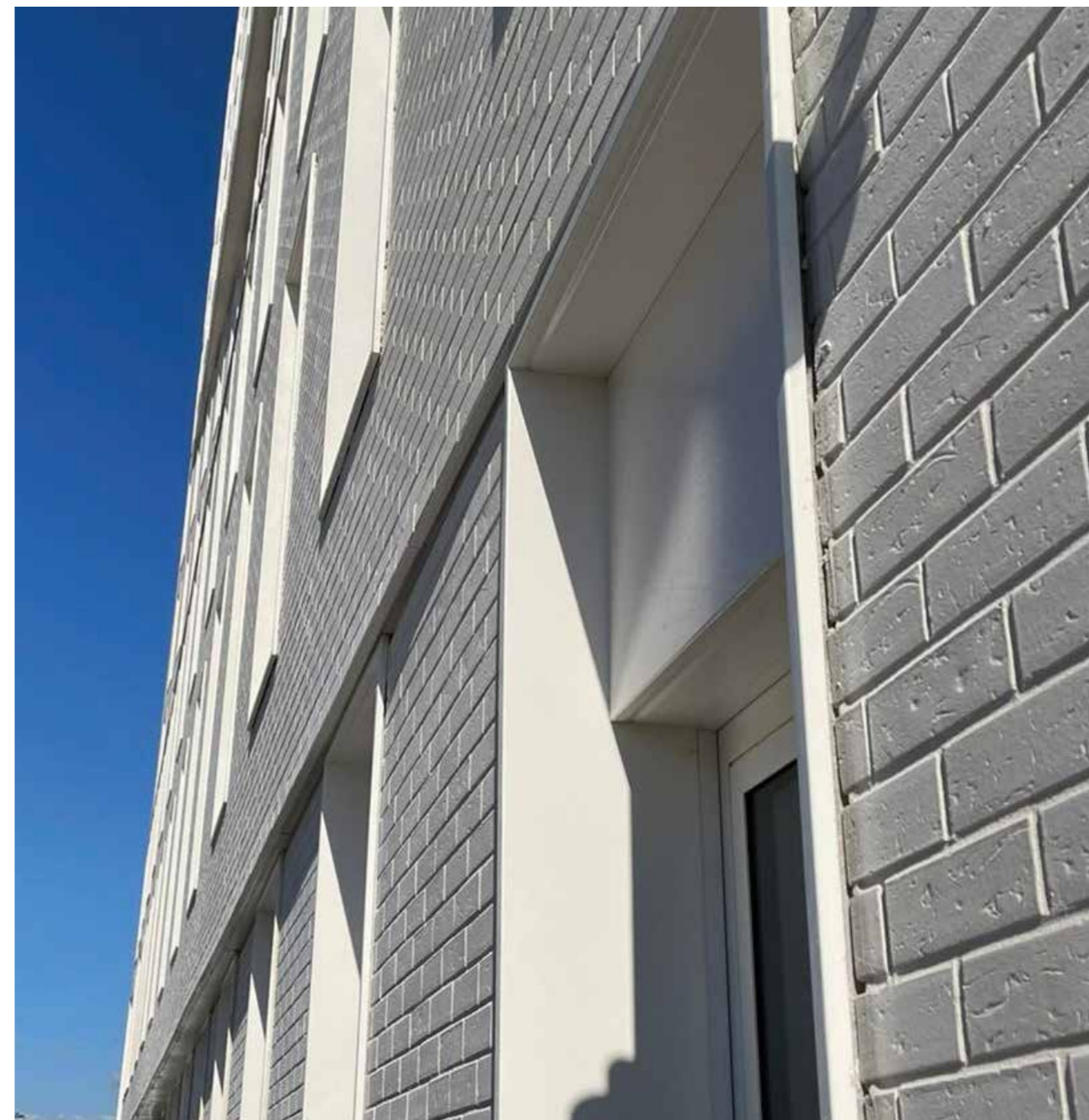

BRUT DE FOUR

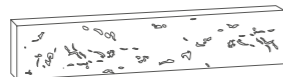

REFERENCE	PRODUCT DESIGNATION	FORMAT L x w x H in mm	QUANTITY sqm or lm	WEIGHT sqm or unit	INDICATIVE QUANTITY		WEIGHT in kg/pallet	SALES UNIT
					sqm/box or u/box	sqm/pallet or u/pallet		
FAP25PF335020-Code	50 mm STRAIGHT	330 x 50 x 20	50/sqm	0,75 Kg/u ou 37,5kg/sqm	0,5 sqm	25 sqm	938 kg	sqm
FAP25PF216520 -Code	65 mm STRAIGHT	215 x 65 x 20	59/sqm	0,65 kg/u ou 37,5kg/sqm	CU	CU	CU	sqm

NEW IN 2024 "CARACTÈRE" RANGE

FAP25PF335015 -Code	50 mm STRAIGHT	330 x 50 x 15	50/sqm	0,65Kg/u ou 32,5kg/sqm	0,5 sqm	25 sqm	938 kg	sqm
---------------------	----------------	---------------	--------	---------------------------	---------	--------	--------	-----

CU = Contact Us - * Sqm = with 10 mm joint

We don't produce angles for this finish.



623 Sahara 0 - α 0,30



624 Mali 0 - α 0,80



622 Séquoia 0 - α 0,76



625 Saturne 0 - α 0,55



620 Saturne 6 - α 0,65



607 Sahara 3 - α 0,34



610 Mali 2 - α 0,85



603 Séquoia 3 - α 0,61



615 Saturne 1 - α 0,72

α = solar absorption coefficient



FLAMED NATURAL TERRACOTTA



REFERENCE	PRODUCT DESIGNATION	FORMAT L x w x H in mm	QUANTITY sqm or lm	WEIGHT sqm or unit	INDICATIVE QUANTITY		WEIGHT in kg/pallet	SALES UNIT
					sqm/box or u/box	sqm/pallet or u/pallet		
FAP21DL226012-Code	60 mm STRAIGHT	220 x 60 x 12	62/sqm	18 kg	0,97 sqm	48,4 sqm	880 kg	sqm
FAP21AL2216012-Code	60 mm CORNER	220 x 105 x 60 x 12	14,3/lm	0,44 kg	50 u	2 050 u	902 kg	unit

* Sqm = with 10 mm joint

Pallet 80 x 120 cm



204 Orion - α 0,57



207 Solesmes - α 0,69



208 Sologne - α 0,55



206 Sirius - α 0,57



209 Villandry - α 0,48

α = solar absorption coefficient

NORMANDY, FLAMED NATURAL TERRACOTTA



REFERENCE	PRODUCT DESIGNATION	FORMAT L x w x H in mm	QUANTITY sqm or lm	WEIGHT sqm or unit	INDICATIVE QUANTITY		WEIGHT in kg/pallet	SALES UNIT
					sqm/box or u/box	sqm/pallet or u/pallet		

FAP21TU286018-Code	BRICK SLIP 280	280 x 60 x 18	50/sqm	24 kg	0,5 sqm	40 sqm	960 kg	sqm
--------------------	----------------	---------------	--------	-------	---------	--------	--------	-----

FAP21TU282518-Code	BAT 280	280 x 25 x 18	99/sqm	23 kg	0,5 sqm	40 sqm	920 kg	unit
--------------------	---------	---------------	--------	-------	---------	--------	--------	------

* Sqm = with 10 mm joint

Pallet 80 x 120 cm

NORMANDY Brick slip



214 Bayeux



216 Trouville



215 Cabourg



217 Deauville

NORMANDY Bat



218 Vimoutiers



219 Verneuil

ORIGINELLE FLAMED NATURAL TERRACOTTA



SMOOTH

REFERENCE	PRODUCT DESIGNATION	FORMAT L x w x H in mm	QUANTITY sqm or lm	WEIGHT sqm or unit	INDICATIVE QUANTITY		WEIGHT in kg /pallet	SALES UNIT
					sqm/box or u/box	sqm/pallet or u/pallet		
FAP21DL226012-Code	60 mm STRAIGHT	220 x 60 x 12	62/sqm	18 kg	0,97 sqm	48,4 sqm	880 kg	sqm
FAP21AL2216012-Code	60 mm CORNER	220 x 105 x 60 x 12	14,3/lm	0,44 kg	50 u	2 100 u	902 kg	unit
FAP21DL335012-Code	50 mm STRAIGHT	330 x 50 x 12	50/sqm	18 kg	0,96 sqm	48 sqm	875 kg	sqm
FAP21AL2215012-Code	50 mm CORNER	220 x 105 x 50 x 12	16,7/lm	0,36 kg	50 u	2 400 u	864 kg	unit
FAP21AL2255012-Code	50 mm CORNER	220 x 50 x 50 x 12	16,7/lm	0,32 kg	50 u	2 700 u	864 kg	unit

* Sqm = with 10 mm joint

Pallet 80 x 120 cm



219 Azay - α 0,41



221 Durtal - α 0,78



220 Valençay - α 0,50



222 Lucé - α 0,71

ORIGINELLE FLAMED NATURAL TERRACOTTA - COLISEE

REFERENCE	PRODUCT DESIGNATION	FORMAT L x w x H in mm	QUANTITY sqm or lm	WEIGHT sqm or unit	INDICATIVE QUANTITY		WEIGHT in kg /pallet	SALES UNIT
					sqm/box or u/box	sqm/pallet or u/pallet		
FAP21DC226012-Code	60 mm STRAIGHT	220 x 60 x 12	62/sqm	18 kg	0,97 sqm	48,4 sqm	880 kg	sqm
FAP21AC2216012-Code	60 mm CORNER	220 x 105 x 60 x 12	14,3/lm	0,44 kg	50 u	2 100 u	902 kg	unit
FAP21DC335012-Code	50 mm STRAIGHT	330 x 50 x 12	50/sqm	18 kg	0,96 sqm	48 sqm	875 kg	sqm
FAP21AC2215012-Code	50 mm CORNER	220 x 105 x 50 x 12	16,7/lm	0,36 kg	50 u	2 400 u	864 kg	unit
FAP21AC2255012-Code	50 mm CORNER	220 x 50 x 50 x 12	16,7/lm	0,32 kg	50 u	2 700 u	864 kg	unit

* Sqm = with 10 mm joint

Pallet 80 x 120 cm



219 Azay - α 0,41



221 Durtal - α 0,78



220 Valençay - α 0,50



222 Lucé - α 0,71

ORIGINELLE FLAMED NATURAL TERRACOTTA - DRAGWIRE

REFERENCE	PRODUCT DESIGNATION	FORMAT L x w x H in mm	QUANTITY sqm or lm	WEIGHT sqm or unit	INDICATIVE QUANTITY		WEIGHT in kg /pallet	SALES UNIT
					sqm/box or u/box	sqm/pallet or u/pallet		
FAP21DA226012-Code	60 mm STRAIGHT	220 x 60 x 12	62/sqm	18 kg	0,97 sqm	48,4 sqm	880 kg	sqm
FAP21AA2216012-Code	60 mm CORNER	220 x 105 x 60 x 12	14,3/lm	0,44 kg	50 u	2 100 u	902 kg	unit
FAP21DA335012-Code	50 mm STRAIGHT	330 x 50 x 12	50/sqm	18 kg	0,96 sqm	48 sqm	875 kg	sqm
FAP21AA2215012-Code	50 mm CORNER	220 x 105 x 50 x 12	16,7/lm	0,36 kg	50 u	2 400 u	864 kg	unit
FAP21AA2255012-Code	50 mm CORNER	220 x 50 x 50 x 12	16,7/lm	0,32 kg	50 u	2 700 u	864 kg	unit

* Sqm = with 10 mm joint

Pallet 80 x 120 cm



219 Azay - α 0,41



221 Durtal - α 0,78



220 Valençay - α 0,50



222 Lucé - α 0,71

ORIGINELLE FLAMED NATURAL TERRACOTTA - BARK

REFERENCE	PRODUCT DESIGNATION	FORMAT L x w x H in mm	QUANTITY sqm or lm	WEIGHT sqm or unit	INDICATIVE QUANTITY		WEIGHT in kg /pallet	SALES UNIT
					sqm/box or u/box	sqm/pallet or u/pallet		
FAP21DE226012-Code	60 mm STRAIGHT	220 x 60 x 12	62/sqm	18 kg	0,97 sqm	48,4 sqm	880 kg	sqm
FAP21AE2216012-Code	60 mm CORNER	220 x 105 x 60 x 12	14,3/lm	0,44 kg	50 u	2 100 u	902 kg	unit
FAP21DE335012-Code	50 mm STRAIGHT	330 x 50 x 12	50/sqm	18 kg	0,96 sqm	48 sqm	875 kg	sqm
FAP21AE2215012-Code	50 mm CORNER	220 x 105 x 50 x 12	16,7/lm	0,36 kg	50 u	2 400 u	864 kg	unit
FAP21AE2255012-Code	50 mm CORNER	220 x 50 x 50 x 12	16,7/lm	0,32 kg	50 u	2 700 u	864 kg	unit

* Sqm = with 10 mm joint

Pallet 80 x 120 cm



219 Azay - α 0,41



221 Durtal - α 0,78



220 Valençay - α 0,50



222 Lucé - α 0,71

α = solar absorption coefficient

PRINCIPLE OF BRICK SLIPS GLAZING

STANDARD BRICK SLIP

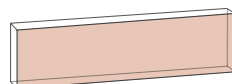

1 side : face

OPTION GLAZING

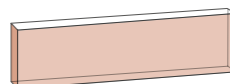

2 sides : face + 1 header

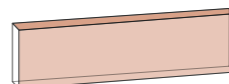

2 sides : face + 1 stretcher

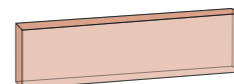

3 sides : face + 1 header + 1 stretcher

SINGLE-FIRED GLAZING



REFERENCE	PRODUCT DESIGNATION	FORMAT L x w x H in mm	QUANTITY sqm or lm	WEIGHT sqm or unit	INDICATIVE QUANTITY		WEIGHT in kg /pallet	SALES UNIT
					sqm/box or u/box	sqm/pallet or u/pallet		
BRICK SLIPS - 12 MM THICKNESS								
FAP29DL226012-Code	60 mm STRAIGHT	220 x 60 x 12	62/sqm	18 kg	0,97 sqm	48,4 sqm	880 kg	sqm
FAP29AL2216012-Code	60 mm CORNER	220 x 105 x 60 x 12	14,3/lm	0,44 kg	50 u	2 100 u	902 kg	unit
FAP29DL335012-Code	50 mm STRAIGHT	330 x 50 x 12	50/sqm	18 kg	0,96 sqm	48 sqm	875 kg	sqm
FAP29AL2215012-Code	50 mm CORNER	220 x 105 x 50 x 12	16,7/lm	0,36 kg	50 u	2 400 u	864 kg	unit
FAP29AL2255012-Code	50 mm CORNER	220 x 50 x 50 x 12	16,7/lm	0,32 kg	50 u	2 700 u	864 kg	unit
FAP29DL216512-Code	65 mm STRAIGHT	215 x 65 x 12	59/sqm	18 kg	1,02 sqm	50,8 sqm	925 kg	sqm
FAP29AL2116512-Code	65 mm CORNER	215 x 102 x 65 x 12	13,3/lm	0,46 kg	50 u	2 100 u	976 kg	unit
FAP29AV2266012-Code	CORNIERE CORNER VERTICAL	220 x 60 x 60 x 12	4,3/lm	0,50 kg	24 u	1 890 u	945 kg	unit
FAP29AV3355012-Code	CORNIERE CORNER VERTICAL	330 x 50 x 50 x 12	3/lm	CU	CU	CU	CU	unit
	VERTICAL CORNER	Other formats are available within the limit of 330 x 60 x 60 x 12 or 220 x 105 x 105 x 12						
FAP29XC225012-Code	CONVEX CURVE Radius 1020 mm	220 x 50 x 12	CU	CU	CU	CU	CU	unit
FAP29XC226012-Code	CONVEX CURVE Radius 1020 mm	220 x 60 x 12	CU	CU	CU	CU	CU	unit
	CONVEX CURVE	Other formats are available for a radius between 160 mm & 2800 mm						
BRICK SLIPS - 15 MM THICKNESS								
FAP29DL226515-Code	65 mm STRAIGHT	220 x 65 x 15	58/sqm	22,5 kg	0,83 sqm	41,4 sqm	931 kg	sqm
FAP29AL2216515-Code	65 mm CORNER	220 x 105 x 65 x 15	13,3/lm	0,55 kg	40 u	1 680 u	924 kg	unit
FAP29DL335015-Code	50 mm STRAIGHT	330 x 50 x 15	50/sqm	22,5 kg	0,72 sqm	36 sqm	820 kg	sqm
FAP29DL455015-Code	50 mm STRAIGHT	450 x 50 x 15	36/sqm	22,5 kg	0,5 sqm	40 sqm	900 kg	sqm
FAP29AL2215015-Code	50 mm CORNER	220 x 105 x 50 x 15	16,7/lm	0,45 kg	40 u	1 920 u	864 kg	unit
FAP29AL2255015-Code	50 mm CORNER	220 x 50 x 50 x 15	16,7/lm	0,4 kg	40 u	2 160 u	864 kg	unit
BRICK SLIPS - 20/25 MM THICKNESS								
FAP29DL226020-Code	60 mm STRAIGHT	220 x 60 x 20	62/sqm	30 kg	0,58 sqm	29 sqm	880 kg	sqm
FAP29AL2216020-Code	60 mm CORNER	220 x 105 x 60 x 20	14,3/lm	0,73 kg	30 u	1 260 u	920 kg	unit
FAP29DL226025-Code	60 mm STRAIGHT	220 x 60 x 25	62/sqm	37,5 kg	0,45 sqm	22,6 sqm	857 kg	sqm
FAP29AL2216025-Code	60 mm CORNER	220 x 105 x 60 x 25	14,3/lm	0,9125 kg	24 u	1 008 u	920 kg	unit
FAP29DL335020-Code	50 mm STRAIGHT	330 x 50 x 20	50/sqm	30 kg	0,6 sqm	30 sqm	910 kg	sqm
FAP29AL2215020-Code	50 mm CORNER	220 x 105 x 50 x 20	16,7/lm	0,6 kg	30 u	1 440 u	864 kg	unit
FAP29DL335025-Code	50 mm STRAIGHT	330 x 50 x 25	50/sqm	37,5 kg	0,48 sqm	24 sqm	910 kg	sqm
FAP29AL2215025-Code	50 mm CORNER	220 x 105 x 50 x 25	16,7/lm	0,75 kg	24 u	1 230 u	922 kg	unit
	OPTION GLAZING HEADER AND STRETCHER							0,53 € header / 0,12 € stretcher / 1,51 € header + stretcher

CU = Contact Us - * Sqm = with 10 mm joint

Pallet 80 x 120 cm

TWICE-FIRED, TRANSPARENT GLAZING



REFERENCE	PRODUCT DESIGNATION	FORMAT L x w x H in mm	QUANTITY sqm or lm	WEIGHT sqm or unit	INDICATIVE QUANTITY		WEIGHT in kg/pallet	SALES UNIT
					sqm/box or u/box	sqm/pallet or u/pallet		
BRICK SLIPS - 12 MM THICKNESS								
FAP27DL226012-Code	60 mm STRAIGHT	220 x 60 x 12	62/sqm	18 kg	0,97 sqm	48,4 sqm	880 kg	sqm
FAP27AL2216012-Code	60 mm CORNER	220 x 105 x 60 x 12	14,3/lm	0,44 kg	50 u	2 100 u	902 kg	unit
FAP27DL335012-Code	50 mm STRAIGHT	330 x 50 x 12	50/sqm	18 kg	0,96 sqm	48 sqm	875 kg	sqm
FAP27AL2215012-Code	50 mm CORNER	220 x 105 x 50 x 12	16,7/lm	0,36 kg	50 u	2 400 u	864 kg	unit
FAP27AL2255012-Code	50 mm CORNER	220 x 50 x 50 x 12	16,7/lm	0,32 kg	50 u	2 700 u	864 kg	unit
FAP27DL216512-Code	65 mm STRAIGHT	215 x 65 x 12	59/sqm	18 kg	1,02 sqm	50,8 sqm	925 kg	sqm
FAP27AL2116512-Code	65 mm CORNER	215 x 102 x 65 x 12	13,3/lm	0,46 kg	50 u	2 100 u	976 kg	unit
FAP27AV2266012-Code	CORNIERE CORNER VERTICAL	220 x 60 x 60 x 12	4,3/lm	0,50 kg	24 u	1 890 u	945 kg	unit
FAP27AV3355012-Code	CORNIERE CORNER VERTICAL	330 x 50 x 50 x 12	3/lm	CU	CU	CU	CU	unit
	CORNIERE CORNER VERTICAL	Other formats are available within the limit of 330 x 60 x 60 x 12 or 220 x 105 x 105						
FAP27XC225012-Code	CONVEX CURVE Radius 1020 mm	220 x 50 x 12	CU	CU	CU	CU	CU	unit
FAP27XC226012-Code	CONVEX CURVE Radius 1020 mm	220 x 60 x 12	CU	CU	CU	CU	CU	unit
	CONVEX CURVE	Other formats are available for a radius between 160 mm & 2800 mm						
BRICK SLIPS - 15 MM THICKNESS								
FAP27DL226515-Code	65 mm STRAIGHT	220 x 65 x 15	58/sqm	22,5 kg	0,83 sqm	41,4 sqm	931 kg	sqm
FAP27AL2216515-Code	65 mm CORNER	220 x 105 x 65 x 15	13,3/lm	0,55 kg	40 u	1 680 u	924 kg	unit
FAP27DL335015-Code	50 mm STRAIGHT	330 x 50 x 15	50/sqm	22,5 kg	0,72 sqm	36 sqm	820 kg	sqm
FAP27DL455015-Code	50 mm STRAIGHT	450 x 50 x 15	36/sqm	22,5 kg	0,5 sqm	40 sqm	900 kg	sqm
FAP27AL2215015-Code	50 mm CORNER	220 x 105 x 50 x 15	16,7/lm	0,45 kg	40 u	1 920 u	864 kg	unit
FAP27AL2255015-Code	50 mm CORNER	220 x 50 x 50 x 15	16,7/lm	0,4 kg	40 u	2 160 u	864 kg	unit
BRICK SLIPS - 20/25 MM THICKNESS								
FAP27DL226020-Code	60 mm STRAIGHT	220 x 60 x 20	62/sqm	30 kg	0,58 sqm	29 sqm	880 kg	sqm
FAP27AL2216020-Code	60 mm CORNER	220 x 105 x 60 x 20	14,3/lm	0,73 kg	30 u	1 260 u	920 kg	unit
FAP27DL226025-Code	60 mm STRAIGHT	220 x 60 x 25	62/sqm	37,5 kg	0,45 sqm	22,6 sqm	857 kg	sqm
FAP27AL2216025-Code	60 mm CORNER	220 x 105 x 60 x 25	14,3/lm	0,9125 kg	24 u	1 008 u	920 kg	unit
FAP27DL335020-Code	50 mm STRAIGHT	330 x 50 x 20	50/sqm	30 kg	0,6 sqm	30 sqm	910 kg	sqm
FAP27AL2215020-Code	50 mm CORNER	220 x 105 x 50 x 20	16,7/lm	0,6 kg	30 u	1 440 u	864 kg	unit
FAP27DL335025-Code	50 mm STRAIGHT	330 x 50 x 25	50/sqm	37,5 kg	0,48 sqm	24 sqm	910 kg	sqm
FAP27AL2215025-Code	50 mm CORNER	220 x 105 x 50 x 25	16,7/lm	0,75 kg	24 u	1 230 u	922 kg	unit
	OPTION GLAZING HEADER AND STRETCHER							0,53 € header / 0,12 € stretcher / 1,51 € header + stretcher

CU = Contact Us - * Sqm = with 10 mm joint

Pallet 80 x 120 cm



401 Blanc Satiné - α 0,24

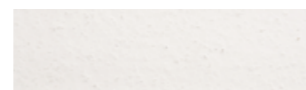

402 Blanc Mat - α 0,31



403 Blanc Brillant - α 0,33



404 Gris 1 - α 0,75



405 Gris 2 - α 0,66



406 Gris 3 - α 0,56



407 Gris 4 - α 0,51



408 Gris 5 - α 0,45



409 MonoRouge 1 - α 0,57



410 MonoVert 5 - α 0,65



411 MonoVert 6 - α 0,70



412 MonoBleu 3 - α 0,65



413 MonoJaune - α 0,49



535 Lumière - α 0,28



541 Havane - α 0,67



537 Montlouis - α 0,55



706 Étain - α 0,38



543 Silver - α 0,56



540 Réglisse - α 0,78



538 Montvaloir - α 0,64



542 Titane - α 0,62



536 Antarès - α 0,46



539 Médoc - α 0,67

NEW IN 2024
This range is also available in Colisee texture

α = solar absorption coefficient

TWICE-FIRED GLAZING



REFERENCE	PRODUCT DESIGNATION	FORMAT L x w x H in mm	QUANTITY sqm or lm	WEIGHT sqm or unit	INDICATIVE QUANTITY		WEIGHT in kg/pallet	SALES UNIT
					sqm/box or u/box	sqm/pallet or u/pallet		
BRICK SLIPS - 12 MM THICKNESS								
FAP27DL226012-Code	60 mm STRAIGHT	220 x 60 x 12	62/sqm	18 kg	0,97 sqm	48,4 sqm	880 kg	sqm
FAP27AL2216012-Code	60 mm CORNER	220 x 105 x 60 x 12	14,3/lm	0,44 kg	50 u	2 100 u	902 kg	unit
FAP27DL335012-Code	50 mm STRAIGHT	330 x 50 x 12	50/sqm	18 kg	0,96 sqm	48 sqm	875 kg	sqm
FAP27AL2215012-Code	50 mm CORNER	220 x 105 x 50 x 12	16,7/lm	0,36 kg	50 u	2 400 u	864 kg	unit
FAP27AL2255012-Code	50 mm CORNER	220 x 50 x 50 x 12	16,7/lm	0,32 kg	50 u	2 700 u	864 kg	unit
FAP27DL216512-Code	65 mm STRAIGHT	215 x 65 x 12	59/sqm	18 kg	1,02 sqm	50,8 sqm	925 kg	sqm
FAP27AL2116512-Code	65 mm CORNER	215 x 102 x 65 x 12	13,3/lm	0,46 kg	50 u	2 100 u	976 kg	unit
FAP27AV2266012-Code	VERTICAL CORNER	220 x 60 x 60 x 12	4,3/lm	0,50 kg	24 u	1 890 u	945 kg	unit
FAP27AV3355012-Code	VERTICAL CORNER	330 x 50 x 50 x 12	3/lm	CU	CU	CU	CU	unit
	VERTICAL CORNER	Other formats are available within the limit of 330 x 60 x 60 x 12 or 220 x 105 x 105						
FAP27XC225012-Code	CONVEX CURVE Radius 1020 mm	220 x 50 x 12	CU	CU	CU	CU	CU	unit
FAP27XC226012-Code	CONVEX CURVE Radius 1020 mm	220 x 60 x 12	CU	CU	CU	CU	CU	unit
	CONVEX CURVE	Other formats are available for a radius between 160 mm & 2800 mm						

BRICK SLIPS - 15 MM THICKNESS								
FAP27DL226515-Code	65 mm STRAIGHT	220 x 65 x 15	58/sqm	22,5 kg	0,83 sqm	41,4 sqm	931 kg	sqm
FAP27AL2216515-Code	65 mm CORNER	220 x 105 x 65 x 15	13,3/lm	0,55 kg	40 u	1 680 u	924 kg	unit
FAP27DL335015-Code	50 mm STRAIGHT	330 x 50 x 15	50/sqm	22,5 kg	0,72 sqm	36 sqm	820 kg	sqm
FAP27DL455015-Code	50 mm STRAIGHT	450 x 50 x 15	36/sqm	22,5 kg	0,5 sqm	40 sqm	900 kg	sqm
FAP27AL2215015-Code	50 mm CORNER	220 x 105 x 50 x 15	16,7/lm	0,45 kg	40 u	1 920 u	864 kg	unit
FAP27AL2255015-Code	50 mm CORNER	220 x 50 x 50 x 15	16,7/lm	0,4 kg	40 u	2 160 u	864 kg	unit

BRICK SLIPS - 20/25 MM THICKNESS								
FAP27DL226020-Code	60 mm STRAIGHT	220 x 60 x 20	62/sqm	30 kg	0,58 sqm	29 sqm	880 kg	sqm
FAP27AL2216020-Code	60 mm CORNER	220 x 105 x 60 x 20	14,3/lm	0,73 kg	30 u	1 260 u	920 kg	unit
FAP27DL226025-Code	60 mm STRAIGHT	220 x 60 x 25	62/sqm	37,5 kg	0,45 sqm	22,6 sqm	857 kg	sqm
FAP27AL2216025-Code	60 mm CORNER	220 x 105 x 60 x 25	14,3/lm	0,9125 kg	24 u	1 008 u	920 kg	unit
FAP27DL335020-Code	50 mm STRAIGHT	330 x 50 x 20	50/sqm	30 kg	0,6 sqm	30 sqm	910 kg	sqm
FAP27AL2215020-Code	50 mm CORNER	220 x 105 x 50 x 20	16,7/lm	0,6 kg	30 u	1 440 u	864 kg	unit
FAP27DL335025-Code	50 mm STRAIGHT	330 x 50 x 25	50/sqm	37,5 kg	0,48 sqm	24 sqm	910 kg	sqm
FAP27AL2215025-Code	50 mm CORNER	220 x 105 x 50 x 25	16,7/lm	0,75 kg	24 u	1 230 u	922 kg	unit

OPTION GLAZING HEADER AND STRETCHER 0,53 € header / 0,12 € stretcher / 1,51 € header + stretcher

CU = Contact Us - * Sqm = with 10 mm joint

Pallet 80 x 120 cm



COLOUR

521 Noir - α 0,90	587 Gris 1 - α 0,74	588 Gris 2 - α 0,72	589 Gris 3 - α 0,62
590 Gris 4 - α 0,51	591 Gris 5 - α 0,35	528 Vanille - α 0,51	511 Chatain - α 0,55
510 Cacao - α 0,69	505 Bleu 1 - α 0,67	506 Bleu 2 - α 0,60	507 Bleu 3 - α 0,67
508 Bleu 4 - α 0,76	514 Jaune - α 0,46	522 Orange - α 0,50	523 Rouge 1 - α 0,57
524 Rouge 2 - α 0,47	525 Rouge 3 - α 0,67	526 Rouge 4 - α 0,47	501 Aubergine 1 - α 0,68
502 Aubergine 2 - α 0,82	509 Brun - α 0,78	529 Vert 1 - α 0,76	530 Vert 2 - α 0,64
531 Vert 3 - α 0,77	532 Vert 4 - α 0,62	533 Vert 5 - α 0,70	534 Vert 6 - α 0,87
704 Beige 1 - α 0,33	503 Blanc Brillant - α 0,39	504 Blanc Mat - α 0,38	

CRYSTAL-CLEAR

544 Flanelle - α 0,55	545 Flanelle nuancé - α 0,55	564 Noyer - α 0,63	565 Noyer nuancé - α 0,63
548 Basalte - α 0,71	549 Basalte nuancé - α 0,71	566 Sureau - α 0,81	567 Sureau nuancé - α 0,81
550 Cosmos - α 0,68	551 Cosmos nuancé - α 0,68	568 Vert d'eau - α 0,61	569 Vert d'eau nuancé - α 0,61
552 Oxygène - α 0,56	553 Oxygène nuancé - α 0,56	570 Sapin - α 0,76	571 Sapin nuancé - α 0,76
554 Océan - α 0,75	555 Océan nuancé - α 0,75	572 Nénuphar - α 0,69	573 Nénuphar nuancé - α 0,69
556 Sable - α 0,47	557 Sable nuancé - α 0,47	574 Laurier - α 0,55	575 Laurier nuancé - α 0,55
558 Frêne - α 0,50	559 Frêne nuancé - α 0,50	576 Eucalyptus - α 0,59	577 Eucalyptus nuancé - α 0,59
560 Merisier - α 0,56	561 Merisier nuancé - α 0,56	578 Lagon - α 0,66	579 Lagon nuancé - α 0,66
562 Chêne - α 0,58	563 Chêne nuancé - α 0,58	701 Coquelicot - α 0,49	702 Coquelicot nuancé - α 0,53

α = solar absorption coefficient

METAL GLAZING



REFERENCE	PRODUCT DESIGNATION	FORMAT L x w x H in mm	QUANTITY sqm or lm	WEIGHT sqm or unit	INDICATIVE QUANTITY		WEIGHT in kg/pallet	SALES UNIT
					sqm/box or u/box	sqm/pallet or u/pallet		
BRICK SLIPS - 12 MM THICKNESS								
FAP27DL226012-Code	60 mm STRAIGHT	220 x 60 x 12	62/sqm	18 kg	0,97 sqm	48,4 sqm	880 kg	sqm
FAP27AL2216012-Code	60 mm CORNER	220 x 105 x 60 x 12	14,3/lm	0,44 kg	50 u	2 100 u	902 kg	unit
FAP27DL335012-Code	50 mm STRAIGHT	330 x 50 x 12	50/sqm	18 kg	0,96 sqm	48 sqm	875 kg	sqm
FAP27AL2215012-Code	50 mm CORNER	220 x 105 x 50 x 12	16,7/lm	0,36 kg	50 u	2 400 u	864 kg	unit
FAP27AL2255012-Code	50 mm CORNER	220 x 50 x 50 x 12	16,7/lm	0,32 kg	50 u	2 700 u	864 kg	unit
FAP27DL216512-Code	65 mm STRAIGHT	215 x 65 x 12	59/sqm	18 kg	1,02 sqm	50,8 sqm	925 kg	sqm
FAP27AL2116512-Code	65 mm CORNER	215 x 102 x 65 x 12	13,3/lm	0,46 kg	50 u	2 100 u	976 kg	unit
FAP27AV2266012-Code	VERTICAL CORNER	220 x 60 x 60 x 12	4,3/lm	0,50 kg	24 u	1 890 u	945 kg	unit
FAP27XC225012-Code	CONVEX CURVE Radius 1020 mm	220 x 50 x 12	CU	CU	CU	CU	CU	unit
FAP27XC226012-Code	CONVEX CURVE Radius 1020 mm	220 x 60 x 12	CU	CU	CU	CU	CU	unit
	CONVEX CURVE	Other formats are available for a radius between 160 mm & 2800 mm						

BRICK SLIPS - 15 MM THICKNESS								
FAP27DL226515-Code	65 mm STRAIGHT	220 x 65 x 15	58/sqm	22,5 kg	0,83 sqm	41,4 sqm	931 kg	sqm
FAP27AL2216515-Code	65 mm CORNER	220 x 105 x 65 x 15	13,3/lm	0,55 kg	40 u	1 680 u	924 kg	unit
FAP27DL335015-Code	50 mm STRAIGHT	330 x 50 x 15	50/sqm	22,5 kg	0,72 sqm	36 sqm	820 kg	sqm
FAP27DL455015-Code	50 mm STRAIGHT	450 x 50 x 15	36/sqm	22,5 kg	0,5 sqm	40 sqm	900 kg	sqm
FAP27AL2215015-Code	50 mm CORNER	220 x 105 x 50 x 15	16,7/lm	0,45 kg	40 u	1 920 u	864 kg	unit
FAP27AL2255015-Code	50 mm CORNER	220 x 50 x 50 x 15	16,7/lm	0,4 kg	40 u	2 160 u	864 kg	unit

BRICK SLIPS - 20/25 MM THICKNESS								
FAP27DL226020-Code	60 mm STRAIGHT	220 x 60 x 20	62/sqm	30 kg	0,58 sqm	29 sqm	880 kg	sqm
FAP27AL2216020-Code	60 mm CORNER	220 x 105 x 60 x 20	14,3/lm	0,73 kg	30 u	1 260 u	920 kg	unit
FAP27DL226025-Code	60 mm STRAIGHT	220 x 60 x 25	62/sqm	37,5 kg	0,45 sqm	22,6 sqm	857 kg	sqm
FAP27AL2216025-Code	60 mm CORNER	220 x 105 x 60 x 25	14,3/lm	0,9125 kg	24 u	1 008 u	920 kg	unit
FAP27DL335020-Code	50 mm STRAIGHT	330 x 50 x 20	50/sqm	30 kg	0,6 sqm	30 sqm	910 kg	sqm
FAP27AL2215020-Code	50 mm CORNER	220 x 105 x 50 x 20	16,7/lm	0,6 kg	30 u	1 440 u	864 kg	unit
FAP27DL335025-Code	50 mm STRAIGHT	330 x 50 x 25	50/sqm	37,5 kg	0,48 sqm	24 sqm	910 kg	sqm
FAP27AL2215025-Code	50 mm CORNER	220 x 105 x 50 x 25	16,7/lm	0,75 kg	24 u	1 230 u	922 kg	unit

OPTION GLAZING HEADER AND STRETCHER

CU = Contact Us - * Sqm = with 10 mm joint

Pallet 80 x 120 cm



516 Fabula - α 0,90

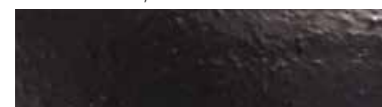

517 Légende - α 0,90



520 Utopie - α 0,85



518 Mirage - α 0,79



515 Cuivre - α 0,56



519 Or - α 0,70



592 Doré - α 0,40



593 Argenté - α 0,39

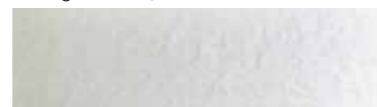

594 Irisé - α 0,31

α = solar absorption coefficient

STONEWARE



REFERENCE	PRODUCT DESIGNATION	FORMAT L x w x H in mm	QUANTITY sqm or lm	WEIGHT sqm or unit	INDICATIVE QUANTITY		WEIGHT in kg/pallet	SALES UNIT
					sqm/box or u/box	sqm/pallet or u/pallet		
BRICK SLIPS - 12 MM THICKNESS								
FAP31DL226012-Code	60 mm STRAIGHT	220 x 60 x 12	62/sqm	18 kg	0,97 sqm	48,4 sqm	880 kg	sqm
FAP31AL2216012-Code	60 mm CORNER	220 x 105 x 60 x 12	14,3/lm	0,44 kg	50 u	2 100 u	902 kg	unit
FAP31DL335012-Code	50 mm STRAIGHT	330 x 50 x 12	50/sqm	18 kg	0,96 sqm	48 sqm	875 kg	sqm
FAP31AL2215012-Code	50 mm CORNER	220 x 105 x 50 x 12	16,7/lm	0,36 kg	50 u	2 400 u	864 kg	unit
FAP31AL2255012-Code	50 mm CORNER	220 x 50 x 50 x 12	16,7/lm	0,32 kg	50 u	2 700 u	864 kg	unit
FAP31DL216512-Code	65 mm STRAIGHT	215 x 65 x 12	59/sqm	18 kg	1,02 sqm	50,8 sqm	925 kg	sqm
FAP31AL2116512-Code	65 mm CORNER	215 x 102 x 65 x 12	13,3/lm	0,46 kg	50 u	2 100 u	976 kg	unit
FAP31AV2266012-Code	VERTICAL CORNER	220 x 60 x 60 x 12	4,3/lm	0,50 kg	24 u	1 890 u	945 kg	unit
FAP31XC225012-Code	CONVEX CURVE Radius 1020 mm	220 x 50 x 12	CU	CU	CU	CU	CU	unit
FAP31XC226012-Code	CONVEX CURVE Radius 1020 mm	220 x 60 x 12	CU	CU	CU	CU	CU	unit
	CONVEX CURVE	Other formats are available for a radius between 160 mm & 2800 mm						

BRICK SLIPS - 15 MM THICKNESS								
FAP31DL226515-Code	65 mm STRAIGHT	220 x 65 x 15	58/sqm	22,5 kg	0,83 sqm	41,4 sqm	931 kg	sqm
FAP31AL2216515-Code	65 mm CORNER	220 x 105 x 65 x 15	13,3/lm	0,55 kg	40 u	1 680 u	924 kg	unit
FAP31DL335015-Code	50 mm STRAIGHT	330 x 50 x 15	50/sqm	22,5 kg	0,72 sqm	36 sqm	820 kg	sqm
FAP31DL455015-Code	50 mm STRAIGHT	450 x 50 x 15	36/sqm	22,5 kg	0,5 sqm	40 sqm	900 kg	sqm
FAP31AL2215015-Code	50 mm CORNER	220 x 105 x 50 x 15	16,7/lm	0,45 kg	40 u	1 920 u	864 kg	unit
FAP31AL2255015-Code	50 mm CORNER	220 x 50 x 50 x 15	16,7/lm	0,4 kg	40 u	2 160 u	864 kg	unit

BRICK SLIPS - 20/25 MM THICKNESS								
FAP31DL226020-Code	60 mm STRAIGHT	220 x 60 x 20	62/sqm	30 kg	0,58 sqm	29 sqm	880 kg	sqm
FAP31AL2216020-Code	60 mm CORNER	220 x 105 x 60 x 20	14,3/lm	0,73 kg	30 u	1 260 u	920 kg	unit
FAP31DL226025-Code	60 mm STRAIGHT	220 x 60 x 25	62/sqm	37,5 kg	0,45 sqm	22,6 sqm	857 kg	sqm
FAP31AL2216025-Code	60 mm CORNER	220 x 105 x 60 x 25	14,3/lm	0,9125 kg	24 u	1 008 u	920 kg	unit
FAP31DL335020-Code	50 mm STRAIGHT	330 x 50 x 20	50/sqm	30 kg	0,6 sqm	30 sqm	910 kg	sqm
FAP31AL2215020-Code	50 mm CORNER	220 x 105 x 50 x 20	16,7/lm	0,6 kg	30 u	1 440 u	864 kg	unit
FAP31DL335025-Code	50 mm STRAIGHT	330 x 50 x 25	50/sqm	37,5 kg	0,48 sqm	24 sqm	910 kg	sqm
FAP31AL2215025-Code	50 mm CORNER	220 x 105 x 50 x 25	16,7/lm	0,75 kg	24 u	1 230 u	922 kg	unit

CU = Contact Us - * Sqm = with 10 mm joint

Pallet 80 x 120 cm

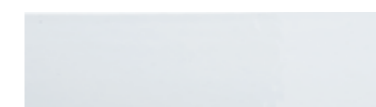

503G Blanc Grès - α 0,39



523G Rouge 1 Grès - α 0,57



521G Noir Grès - α 0,90



507G Bleu 3 Grès - α 0,67



512G Gris 1 Grès - α 0,74

α = solar absorption coefficient

BRICK SLIPS SPECIAL SHAPES

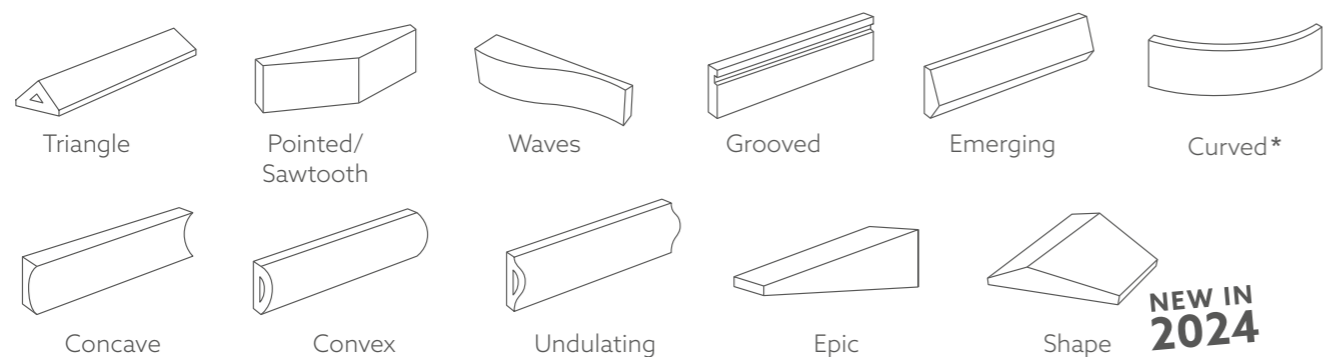

NATURAL TERRACOTTA



Colour references: see page 15

REFERENCE	PRODUCT DESIGNATION	FORMAT L x w x H in mm	QUANTITY sqm	WEIGHT sqm	INDICATIVE QUANTITY		WEIGHT in kg /pallet	SALES UNIT
					sqm/box or u/box	sqm/pallet or u/pallet		
FAP20FF226024-Code	TRIANGLE	220 x 60 x 12/24	62/sqm	25 kg	0,6 sqm/ 37 u	30 sqm	750 kg	unit
FAP20FF335024-Code	TRIANGLE	330 x 50 x 12/24	50/sqm	23 kg	0,64 sqm/ 32 u	32 sqm	736 kg	unit
FAP20FG226035-Code	POINTED	220 x 60 x 12/35	62/sqm	36,5 kg	0,35 sqm/ 22 u	17,5 sqm	639 kg	unit
FAP20FI226035-Code	POINTED	220 x 60 x 12/35 1/3	62/sqm	36,5 kg	0,35 sqm/ 22 u	17,5 sqm	639 kg	unit
FAP20FH226030-Code	WAVES	220 x 60 x 12/30	62/sqm	32,2 kg	0,5 sqm	25 sqm	805 kg	unit
FAP20FD226012-Code	GROOVED	220 x 60 x 8/12	62/sqm	18 kg	62 u	50 sqm	900 kg	unit
FAP20FD335012-Code	GROOVED	330 x 50 x 8/12	50/sqm	18 kg	51 u	49 sqm	882 kg	unit
FAP20FC226024-Code	EMERGING	220 x 60 x 12/24	62/sqm	24 kg	0,6 sqm	30 sqm	720 kg	unit
FAP20FC335024-Code	EMERGING	330 x 50 x 12/24	50/sqm	28,5 kg	0,5 sqm	25 sqm	712 kg	unit
FAP20FB226024-Code	CONCAVE	220 x 60 x 12/24	62/sqm	19 kg	0,5 sqm	25 sqm	475 kg	unit
FAP20FB335024-Code	CONCAVE	330 x 50 x 12/24	50/sqm	23 kg	0,5 sqm	25 sqm	57 kg	unit
FAP20FB336024-Code	CONCAVE	330 x 60 x 12/24	42/sqm	CU	CU	CU	CU	unit
FAP20FA226024-Code	CONVEX	220 x 60 x 12/24	62/sqm	28 kg	0,5 sqm	25 sqm	700 kg	unit
FAP20FA335024-Code	CONVEX	330 x 50 x 12/24	50/sqm	34 kg	0,5 sqm	25 sqm	850 kg	unit
FAP20FJ337124-Code	UNDULATING	330 x 71 x 12/24	36/sqm	23,5 kg	0,45 sqm	22,5 sqm	529 kg	unit
FAP20FE226035-Code	EPIC	220 x 60 x 35/12	62/sqm	38,4 kg	0,5 sqm	25 sqm	960 kg	unit
FAP20FE226024-Code	EPIC	220 x 60 x 24/12	62/sqm	25,4 kg	0,7 sqm	35 sqm	889 kg	unit
FAP20FM14102L-Code	SHAPE	145/70 x 100 x 15/25	100/sqm	27 kg	0,4 sqm	20 sqm	540 kg	unit

CU = Contact Us - * Curved: for more informations, please refer to page 15

Pallet 80 x 120 cm

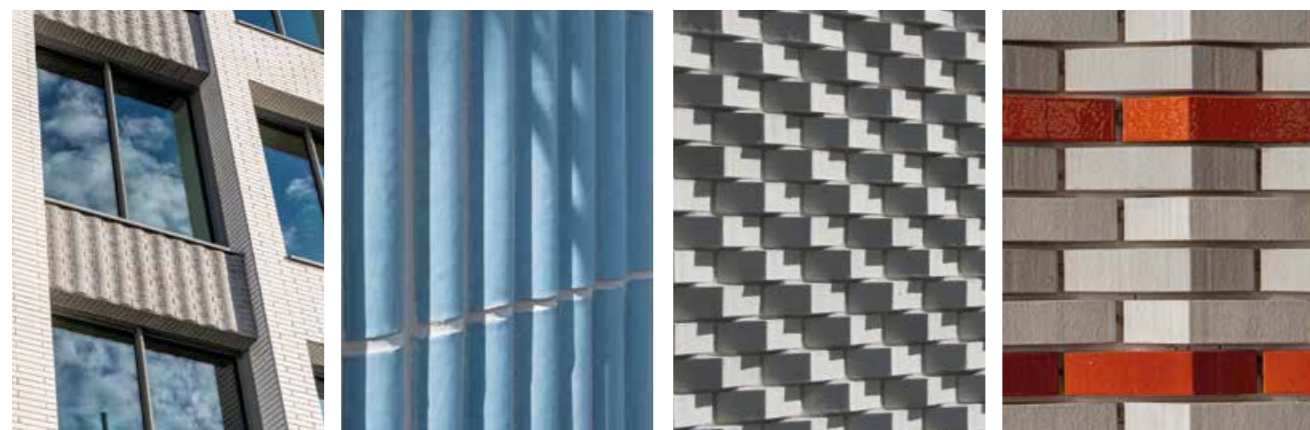

ENGOBED, COLOURED TERRACOTTA



Colour references: see page 21

REFERENCE	PRODUCT DESIGNATION	FORMAT L x w x H in mm	QUANTITY sqm	WEIGHT sqm	INDICATIVE QUANTITY		WEIGHT in kg /pallet	SALES UNIT
					sqm/box or u/box	sqm/pallet or u/pallet		
FAP22FF226024-Code	TRIANGLE	220 x 60 x 12/24	62/sqm	25 kg	0,6 sqm/ 37 u	30 sqm	750 kg	unit
FAP22FF335024-Code	TRIANGLE	330 x 50 x 12/24	50/sqm	23 kg	0,64 sqm/ 32 u	32 sqm	736 kg	unit
FAP22FG226035-Code	POINTED	220 x 60 x 12/35	62/sqm	36,5 kg	0,35 sqm/ 22 u	17,5 sqm	639 kg	unit
FAP22FI226035-Code	POINTED	220 x 60 x 12/35 1/3	62/sqm	36,5 kg	0,35 sqm/ 22 u	17,5 sqm	639 kg	unit
FAP22FH226030-Code	WAVES	220 x 60 x 12/30	62/sqm	32,2 kg	0,5 sqm	25 sqm	805 kg	unit
FAP22FD226012-Code	GROOVED	220 x 60 x 8/12	62/sqm	18 kg	62 u	50 sqm	900 kg	unit
FAP22FD335012-Code	GROOVED	330 x 50 x 8/12	50/sqm	18 kg	51 u	49 sqm	882 kg	unit
FAP22FC226024-Code	EMERGING	220 x 60 x 12/24	62/sqm	24 kg	0,6 sqm	30 sqm	720 kg	unit
FAP22FC335024-Code	EMERGING	330 x 50 x 12/24	50/sqm	28,5 kg	0,5 sqm	25 sqm	712 kg	unit
FAP22FB226024-Code	CONCAVE	220 x 60 x 12/24	62/sqm	19 kg	0,5 sqm	25 sqm	475 kg	unit
FAP22FB335024-Code	CONCAVE	330 x 50 x 12/24	50/sqm	23 kg	0,5 sqm	25 sqm	57 kg	unit
FAP22FB336024-Code	CONCAVE	330 x 60 x 12/24	42/sqm	CU	CU	CU	CU	unit
FAP22FA226024-Code	CONVEX	220 x 60 x 12/24	62/sqm	28 kg	0,5 sqm	25 sqm	700 kg	unit
FAP22FA226024-Code	CONVEX	330 x 50 x 12/24	50/sqm	34 kg	0,5 sqm	25 sqm	850 kg	unit
FAP22FJ337124-Code	UNDULATING	330 x 71 x 12/24	36/sqm	23,5 kg	0,45 sqm	22,5 sqm	529 kg	unit
FAP22FE226035-Code	EPIC	220 x 60 x 35/12	62/sqm	38,4 kg	0,5 sqm	25 sqm	960 kg	unit
FAP22FE226024-Code	EPIC	220 x 60 x 24/12	62/sqm	25,4 kg	0,7 sqm	35 sqm	889 kg	unit
FAP22FM14102L-Code	SHAPE	145/70 x 100 x 15/25	100/sqm	27 kg	0,4 sqm	20 sqm	540 kg	unit

CU = Contact Us - * Curved: for more informations, please refer to page 20

Pallet 80 x 120 cm

SINGLE-FIRED & TWICE-FIRED GLAZING



Colour references: see page 28/29/31

REFERENCE	PRODUCT DESIGNATION	FORMAT L x w x H in mm	QUANTITY sqm	WEIGHT sqm	INDICATIVE QUANTITY		WEIGHT in kg /pallet	SALES UNIT
					sqm/box or u/box	sqm/pallet or u/pallet		
FAP27FF226024-Code	TRIANGLE	220 x 60 x 12/24	62/sqm	25 kg	0,6 sqm/ 37 u	30 sqm	750 kg	unit
FAP27FF335024-Code	TRIANGLE	330 x 50 x 12/24	50/sqm	23 kg	0,64 sqm/ 32 u	32 sqm	736 kg	unit
FAP27FG226035-Code	POINTED	220 x 60 x 12/35	62/sqm	36,5 kg	0,35 sqm/ 22 u	17,5 sqm	639 kg	unit
FAP27FI226035-Code	POINTED	220 x 60 x 12/35 1/3	62/sqm	36,5 kg	0,35 sqm/ 22 u	17,5 sqm	639 kg	unit
FAP27FH226030-Code	WAVES	220 x 60 x 12/30	62/sqm	32,2 kg	0,5 sqm	25 sqm	805 kg	unit
FAP27FD226012-Code	GROOVED	220 x 60 x 8/12	62/sqm	18 kg	62 u	50 sqm	900 kg	unit
FAP27FD335012-Code	GROOVED	330 x 50 x 8/12	50/sqm	18 kg	51 u	49 sqm	882 kg	unit
FAP27FC226024-Code	EMERGING	220 x 60 x 12/24	62/sqm	24 kg	0,6 sqm	30 sqm	720 kg	unit
FAP27FC335024-Code	EMERGING	330 x 50 x 12/24	50/sqm	28,5 kg	0,5 sqm	25 sqm	712 kg	unit
FAP27FB226024-Code	CONCAVE	220 x 60 x 12/24	62/sqm	19 kg	0,5 sqm	25 sqm	475 kg	unit
FAP27FB335024-Code	CONCAVE	330 x 50 x 12/24	50/sqm	23 kg	0,5 sqm	25 sqm	57 kg	unit
FAP27FB336024-Code	CONCAVE	330 x 60 x 12/24	42/sqm	CU	CU	CU	CU	unit
FAP27FA226024-Code	CONVEX	220 x 60 x 12/24	62/sqm	28 kg	0,5 sqm	25 sqm	700 kg	unit
FAP27FA335024-Code	CONVEX	330 x 50 x 12/24	50/sqm	34 kg	0,5 sqm	25 sqm	850 kg	unit
FAP27FJ337124-Code	UNDULATING	330 x 71 x 12/24	36/sqm	23,5 kg	0,45 sqm	22,5 sqm	529 kg	unit
FAP27FE226035-Code	EPIC	220 x 60 x 35/12	62/sqm	38,4 kg	0,5 sqm	25 sqm	960 kg	unit
FAP27FE226024-Code	EPIC	220 x 60 x 24/12	62/sqm	25,4 kg	0,7 sqm	35 sqm	889 kg	unit
FAP27FM14102L-Code	SHAPE	145/70 x 100 x 15/25	100/sqm	27 kg	0,4 sqm	20 sqm	540 kg	unit

CU = Contact Us - * Curved: for more informations, please refer to page 32, 33, 35

Pallet 80 x 120 cm

BRICK SLIPS SPECIAL SHAPES

METAL GLAZING  Colour references: see page 32

REFERENCE	PRODUCT DESIGNATION	FORMAT L x w x H in mm	QUANTITY sqm	WEIGHT sqm	INDICATIVE QUANTITY		WEIGHT in kg /pallet	SALES UNIT
					sqm/box or u/box	sqm/pallet or u/pallet		
FAP27FF226024-Code	TRIANGLE	220 x 60 x 12/24	62/sqm	25 kg	0,6 sqm/ 37 u	30 sqm	750 kg	unit
FAP27FF335024-Code	TRIANGLE	330 x 50 x 12/24	50/sqm	23 kg	0,64 sqm/ 32 u	32 sqm	736 kg	unit
FAP27FG226035-Code	POINTED	220 x 60 x 12/35	62/sqm	36,5 kg	0,35 sqm/ 22 u	17,5 sqm	639 kg	unit
FAP27FI226035-Code	POINTED	220 x 60 x 12/35 1/3	62/sqm	36,5 kg	0,35 sqm/ 22 u	17,5 sqm	639 kg	unit
FAP27FH226030-Code	WAVES	220 x 60 x 12/30	62/sqm	32,2 kg	0,5 sqm	25 sqm	805 kg	unit
FAP27FD226012-Code	GROOVED	220 x 60 x 8/12	62/sqm	18 kg	62 u	50 sqm	900 kg	unit
FAP27FD335012-Code	GROOVED	330 x 50 x 8/12	50/sqm	18 kg	51 u	49 sqm	882 kg	unit
FAP27FC226024-Code	EMERGING	220 x 60 x 12/24	62/sqm	24 kg	0,6 sqm	30 sqm	720 kg	unit
FAP27FC335024-Code	EMERGING	330 x 50 x 12/24	50/sqm	28,5 kg	0,5 sqm	25 sqm	712 kg	unit
FAP27FB226024-Code	CONCAVE	220 x 60 x 12/24	62/sqm	19 kg	0,5 sqm	25 sqm	475 kg	unit
FAP27FB335024-Code	CONCAVE	330 x 50 x 12/24	50/sqm	23 kg	0,5 sqm	25 sqm	57 kg	unit
FAP22FB336024-Code	CONCAVE	330 x 60 x 12/24	42/sqm	CU	CU	CU	CU	unit
FAP27FA226024-Code	CONVEX	220 x 60 x 12/24	62/sqm	28 kg	0,5 sqm	25 sqm	700 kg	unit
FAP27FA335024-Code	CONVEX	330 x 50 x 12/24	50/sqm	34 kg	0,5 sqm	25 sqm	850 kg	unit
FAP27FJ337124-Code	UNDULATING	330 x 71 x 12/24	36/sqm	23,5 kg	0,45 sqm	22,5 sqm	529 kg	unit
FAP27FE226035-Code	EPIC	220 x 60 x 35/12	62/sqm	38,4 kg	0,5 sqm	25 sqm	960 kg	unit
FAP27FE226024-Code	EPIC	220 x 60 x 24/12	62/sqm	25,4 kg	0,7 sqm	35 sqm	889 kg	unit
FAP27FM14102L-Code	SHAPE	145/70 x 100 x 15/25	100/sqm	27 kg	0,4 sqm	20 sqm	540 kg	unit

CU = Contact Us - * Curved: for more informations, please refer to page 36

Pallet 80 x 120 cm

COSTE PROFILE



COSTE PROFILE

BRICKS

ACROBRIC

TILES

PAVING STONES

SCREEN WALLS

GENERAL SALESTERMS
AND CONDITIONS

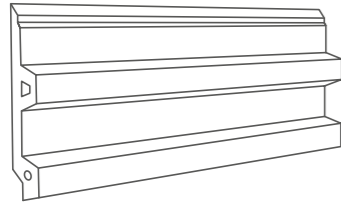

Coste profile

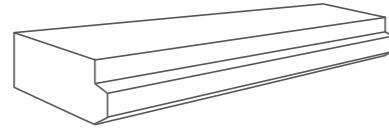

Coste profile brick

NATURAL TERRACOTTA



Colour references: see page 15

REFERENCE	MODEL	FORMAT L x w x H in mm	NUMBER per sqm or lm	WEIGHT /sqm or /u	QUANTITY sqm/pallet or u/pallet	WEIGHT in kg /pallet	SALES UNIT
FAP20PC231330-Code	COSTE PROFILE	230 x 130 x 12	36/sqm	28,08 kg	23,6 sqm	663 kg	le m ²
FAP20BF23501E-Code	COSTE PROFILE BRICK	230 x 50 x 90/105	69/sqm	2,2 kg	450 u	990 kg	unit
FAP20BF33501E-Code	COSTE PROFILE BRICK	330 x 50 x 90/105	50/sqm	3,15 kg	315 u	992 kg	unit

Pallet 80 x 120 cm

ENGOBED & TWICE-FIRED GLAZING



Colour references: see pages 20/29/31

REFERENCE	MODEL	FORMAT L x w x H in mm	NUMBER per sqm or lm	WEIGHT /sqm or /u	QUANTITY sqm/pallet or u/pallet	WEIGHT in kg /pallet	SALES UNIT
FAP27PC231330-Code	COSTE PROFILE	230 x 130 x 12	36/sqm	28,08 kg	23,6 sqm	663 kg	le m ²
FAP27BF23501E-Code	COSTE PROFILE BRICK	230 x 50 x 90/105	69/sqm	2,2 kg	450 u	990 kg	unit
FAP27BF33501E-Code	COSTE PROFILE BRICK	330 x 50 x 90/105	50/sqm	3,15 kg	315 u	992 kg	unit

Pallet 80 x 120 cm

METAL GLAZING



Colour references: see page 32

REFERENCE	MODEL	FORMAT L x w x H in mm	NUMBER per sqm or lm	WEIGHT /sqm or /u	QUANTITY sqm/pallet or u/pallet	WEIGHT in kg /pallet	SALES UNIT
FAP27PC231330-Code	COSTE PROFILE	230 x 130 x 12	36/sqm	28,08 kg	23,6 sqm	663 kg	le m ²
FAP27BF23501E-Code	COSTE PROFILE BRICK	230 x 50 x 90/105	69/sqm	2,2 kg	450 u	990 kg	unit
FAP27BF33501E-Code	COSTE PROFILE BRICK	330 x 50 x 90/105	50/sqm	3,15 kg	315 u	992 kg	unit

Pallet 80 x 120 cm

BRICKS

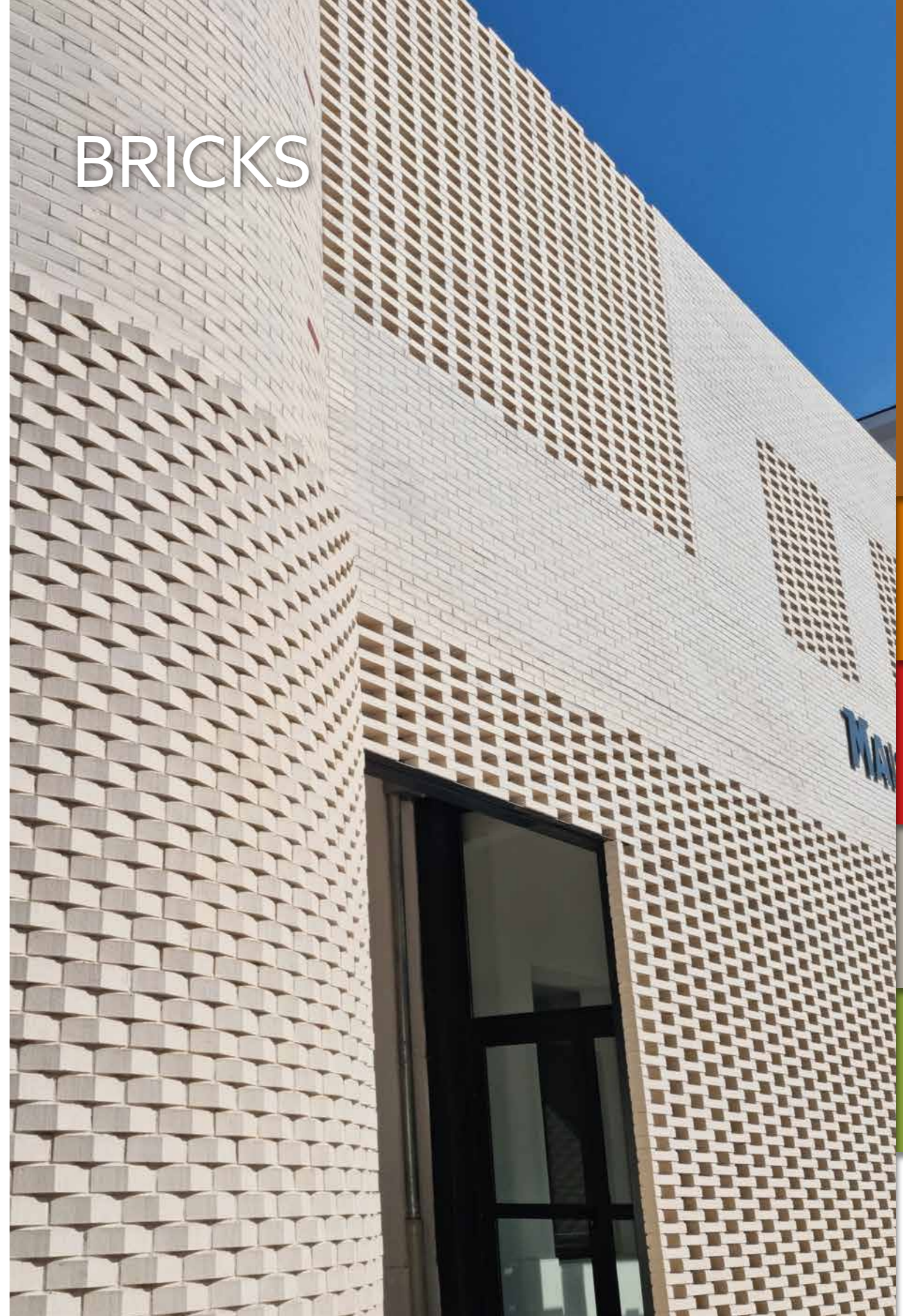

BRICKS

ACROBRIC

TILES

PAVING STONES

SCREEN WALLS

GENERAL SALESTERMS
AND CONDITIONS

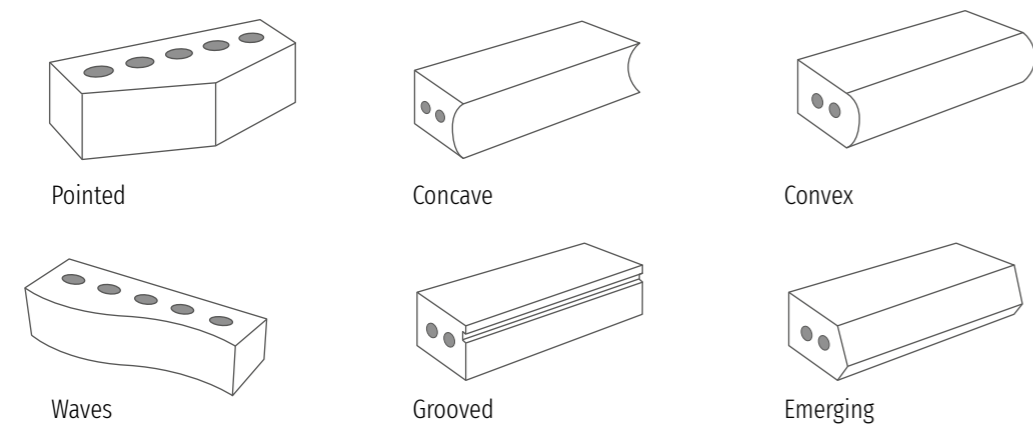
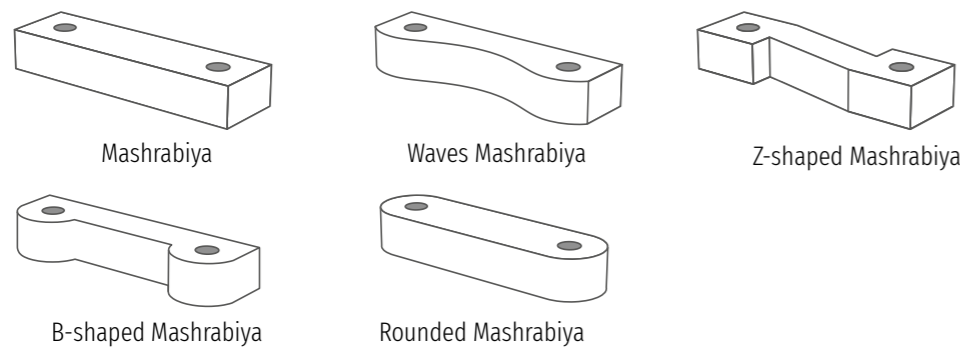
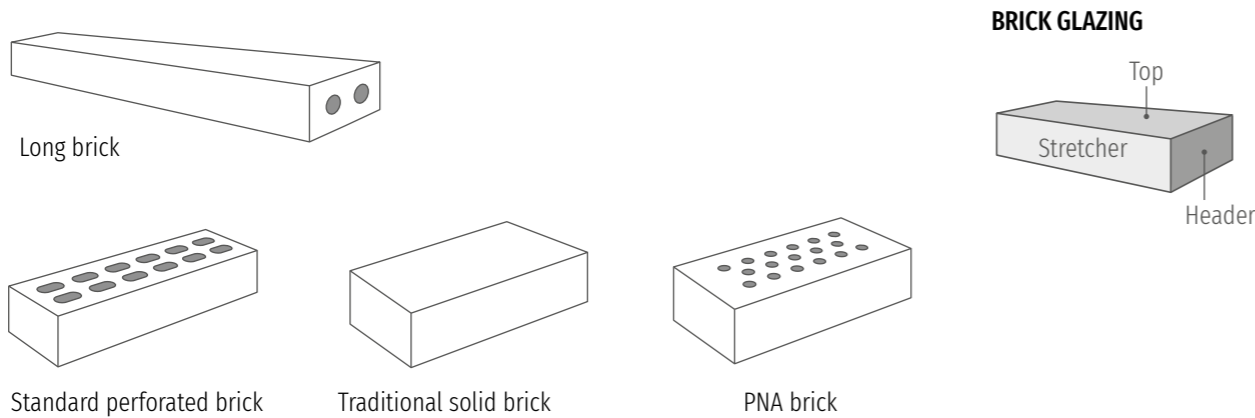

All brick types are available in a solid version to address the needs for corners.

NATURAL TERRACOTTA - SMOOTH



REFERENCE	BRICK MODEL	FORMAT L x H x t / w in mm	NUMBER per sqm	WEIGHT /sqm or /u	QUANTITY sqm/pallet or u/pallet	WEIGHT in kg/pallet	SALES UNIT
FAP20BL226090-Code	STANDARD	220 x 60 x 90	62/sqm	2,3 kg	500 u	1 150 kg	unit
FAP20BL225090-Code	STANDARD	220 x 50 x 90	72/sqm	1,9 kg	500 u	950 kg	unit
FAP20BL335090-Code	STANDARD	330 x 50 x 90	50/sqm	2,85 kg	350 u	998 kg	unit
FAP20BP335090-Code	STANDARD	330 x 50 x 90	50/sqm	2,31 kg	400 u	924 kg	unit
FAP20BL225010-Code	TRADITIONAL	220 x 50 x 105	72/sqm	2,125 kg	500 u	1 065 kg	unit
FAP20BN225010-Code	PNA	220 x 50 x 105	72/sqm	1,77 kg	600 u	1 062 kg	unit
FAP20BL226010-Code	TRADITIONAL	220 x 60 x 105	62/sqm	2,55 kg	500 u	1 275 kg	unit
FAP20BN226010-Code	PNA	220 x 60 x 105	62/sqm	2,12 kg	500 u	1 060 kg	unit
FAP20BM22690-Code	MASHRABIYA	220 x 60 x 90	56/sqm	2,20 kg	500 u	1 100 kg	unit
FAP20BM22601-Code	MASHRABIYA	220 x 60 x 105	56/sqm	2,60 kg	500 u	1 210 kg	unit
FAP20BM33509L-Code	MASHRABIYA	330 x 50 x 90	35/sqm	2,70 kg	350 u	945 kg	unit
FAP20BM33509Z-Code	Z-SHAPED MASHRABIYA	330 x 50 x 90	35/sqm	2,70 kg	350 u	945 kg	unit
FAP20BM33509H-Code	WAVES MASHRABIYA	330 x 50 x 90	35/sqm	2,70 kg	350 u	945 kg	unit
FAP20BM33509B-Code	B-SHAPED MASHRABIYA	330 x 50 x 90	35/sqm	2,70 kg	350 u	945 kg	unit
FAP20BM33509R-Code	ROUNDED MASHRABIYA	330 x 50 x 90	35/sqm	2,70 kg	350 u	945 kg	unit
FAP20PL216510-Code	POINTED	215 x 65 x 102	59/sqm	2,44 kg	387 u	945 kg	unit
FAP20HL226011-Code	WAVES	220 x 60 x 115	62/sqm	1,75 kg	546 u	956 kg	unit
FAP20BF22609B-Code	CONCAVE	220 x 60 x 90	62/sqm	2,50 kg	384 u	960 kg	unit
FAP20BF33509B-Code	CONCAVE	330 x 50 x 90	50/sqm	3,13 kg	300 u	939 kg	unit
FAP20BF22609A-Code	CONVEX	220 x 60 x 90	62/sqm	1,98 kg	500 u	990 kg	unit
FAP20BF33509A-Code	CONVEX	330 x 50 x 90	50/sqm	3,2 kg	300 u	900 kg	unit
FAP20BF22609D-Code	GROOVED	220 x 60 x 90	62/sqm	2,24 kg	500 u	1 120 kg	unit
FAP20BF33509D-Code	GROOVED	330 x 50 x 90	50/sqm	2,80 kg	350 u	980 kg	unit
FAP20BF22609C-Code	EMERGING	220 x 60 x 90	62/sqm	2,47 kg	400 u	988 kg	unit
FAP20BF33509C-Code	EMERGING	330 x 50 x 90	50/sqm	3,09 kg	300 u	927 kg	unit

Pallet 80 x 120 cm



103 Lumière



109 Silver



110 Titane



116 Étain



102 Havane



108 Régliste



101 Antarès



105 Montlouis



106 Montvaloir



104 Médoc

NATURAL TERRACOTTA - COLISEE

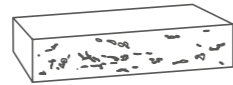

REFERENCE	BRICK MODEL	FORMAT L x H x t / w in mm	NUMBER per sqm	WEIGHT /sqm or /u	QUANTITY sqm/pallet or u/pallet	WEIGHT in kg/pallet	SALES UNIT
FAP20BC226090-Code	STANDARD	220 x 60 x 90	62/sqm	2,3 kg	500 u	1 150 kg	unit
FAP20BC225090-Code	STANDARD	220 x 50 x 90	72/sqm	1,9 kg	500 u	950 kg	unit
FAP20BC335090-Code	STANDARD	330 x 50 x 90	50/sqm	2,85 kg	350 u	998 kg	unit
FAP20BP33509C-Code	STANDARD	330 x 50 x 90	50/sqm	2,31 kg	400 u	924 kg	unit
FAP20BC225010-Code	TRADITIONAL	220 x 50 x 105	72/sqm	2,125 kg	500 u	1 065 kg	unit
FAP20BN22501C-Code	PNA	220 x 50 x 105	72/sqm	1,77 kg	500 u	885 kg	unit
FAP20BC226010-Code	TRADITIONAL	220 x 60 x 105	62/sqm	2,55 kg	500 u	1 275 kg	unit
FAP20BN22601C-Code	PNA	220 x 60 x 105	62/sqm	2,12 kg	500 u	1 060 kg	unit
FAP20BM22609C-Code	MASHRABIYA	220 x 60 x 90	56/sqm	2,20 kg	500 u	1 100 kg	unit
FAP20BM22601C-Code	MASHRABIYA	220 x 60 x 105	56/sqm	2,42 kg	500 u	1 300 kg	unit
FAP20BM33509C-Code	MASHRABIYA	330 x 50 x 90	35/sqm	2,70 kg	350 u	1 080 kg	unit

Pallet 80 x 120 cm



NATURAL TERRACOTTA - DRAGWIRE



REFERENCE	BRICK MODEL	FORMAT L x H x t / w in mm	NUMBER per sqm	WEIGHT /sqm or /u	QUANTITY sqm/pallet or u/pallet	WEIGHT in kg/pallet	SALES UNIT
FAP20BA226090-Code	STANDARD	220 x 60 x 90	62/sqm	2,3 kg	500 u	1 150 kg	unit
FAP20BA225090-Code	STANDARD	220 x 50 x 90	72/sqm	1,9 kg	500 u	950 kg	unit
FAP20BA335090-Code	STANDARD	330 x 50 x 90	50/sqm	2,85 kg	350 u	998 kg	unit
FAP20BP33509A-Code	STANDARD	330 x 50 x 90	50/sqm	2,31 kg	400 u	924 kg	unit
FAP20BA225010-Code	TRADITIONAL	220 x 50 x 105	72/sqm	2,125 kg	500 u	1 065 kg	unit
FAP20BN22501A-Code	PNA	220 x 50 x 105	72/sqm	1,77 kg	500 u	885 kg	unit
FAP20BA226010-Code	TRADITIONAL	220 x 60 x 105	62/sqm	2,55 kg	500 u	1 275 kg	unit
FAP20BN22601A-Code	PNA	220 x 60 x 105	62/sqm	2,12 kg	500 u	1 060 kg	unit
FAP20BM22609A-Code	MASHRABIYA	220 x 60 x 90	56/sqm	2,20 kg	500 u	1 100 kg	unit
FAP20BM22601A-Code	MASHRABIYA	220 x 60 x 105	56/sqm	2,42 kg	500 u	1 300 kg	unit
FAP20BM33509A-Code	MASHRABIYA	330 x 50 x 90	35/sqm	2,70 kg	350 u	1 080 kg	unit

Pallet 80 x 120 cm



NATURAL TERRACOTTA - BARK

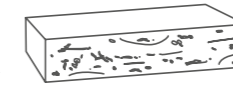

REFERENCE	BRICK MODEL	FORMAT L x H x t / w in mm	NUMBER per sqm	WEIGHT /sqm or /u	QUANTITY sqm/pallet or u/pallet	WEIGHT in kg/pallet	SALES UNIT
FAP20BE226090-Code	STANDARD	220 x 60 x 90	62/sqm	2,3 kg	500 u	1 150 kg	unit
FAP20BE225090-Code	STANDARD	220 x 50 x 90	72/sqm	1,9 kg	500 u	950 kg	unit
FAP20BE335090-Code	STANDARD	330 x 50 x 90	50/sqm	2,85 kg	350 u	998 kg	unit
FAP20BP33509E-Code	STANDARD	330 x 50 x 90	50/sqm	2,31 kg	400 u	924 kg	unit
FAP20BE225010-Code	TRADITIONAL	220 x 50 x 105	72/sqm	2,125 kg	500 u	1 065 kg	unit
FAP20BN22501E-Code	PNA	220 x 50 x 105	72/sqm	1,77 kg	500 u	885 kg	unit
FAP20BE226010-Code	TRADITIONAL	220 x 60 x 105	62/sqm	2,55 kg	500 u	1 275 kg	unit
FAP20BN22601E-Code	PNA	220 x 60 x 105	62/sqm	2,12 kg	500 u	1 060 kg	unit
FAP20BM22609E-Code	MASHRABIYA	220 x 60 x 90	56/sqm	2,20 kg	500 u	1 100 kg	unit
FAP20BM22601E-Code	MASHRABIYA	220 x 60 x 105	56/sqm	2,42 kg	500 u	1 300 kg	unit
FAP20BM33509E-Code	MASHRABIYA	330 x 50 x 90	35/sqm	2,70 kg	350 u	1 080 kg	unit

Pallet 80 x 120 cm



PRINCIPLE OF GLAZING THE BRICKS

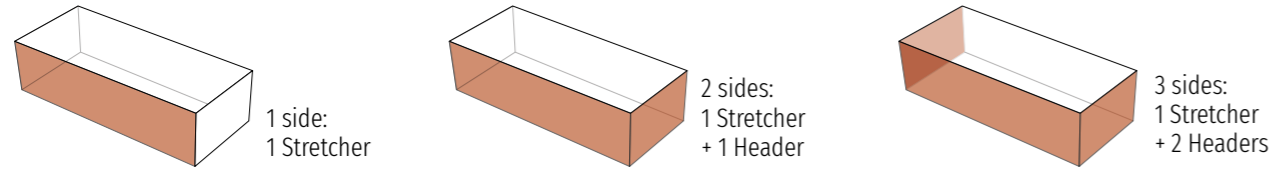

ENGOBED, COLOURED TERRACOTTA - SMOOTH



REFERENCE	BRICK MODEL	FORMAT L x H x t / w in mm	NUMBER per sqm	WEIGHT /sqm or /u	QUANTITY sqm/pallet or u/pallet	WEIGHT in kg/pallet	SALES UNIT
GLAZED - 1 SIDE							
FAP22BL226090-Code	STANDARD	220 x 60 x 90	62/sqm	2,3 kg	500 u	1 150 kg	unit
FAP22BL225090-Code	STANDARD	220 x 50 x 90	72/sqm	1,9 kg	500 u	950 kg	unit
FAP22BL335090-Code	STANDARD	330 x 50 x 90	50/sqm	2,85 kg	350 u	998 kg	unit
FAP22BP335090-Code	STANDARD	330 x 50 x 90	50/sqm	2,31 kg	400 u	924 kg	unit
FAP22BL225010-Code	TRADITIONAL	220 x 50 x 105	72/sqm	2,125 kg	500 u	1 065 kg	unit
FAP22BN225010-Code	PNA	220 x 50 x 105	72/sqm	1,77 kg	500 u	885 kg	unit
FAP22BL226010-Code	TRADITIONAL	220 x 60 x 105	62/sqm	2,55 kg	500 u	1 275 kg	unit
FAP22BN226010-Code	PNA	220 x 60 x 105	62/sqm	2,12 kg	500 u	1 060 kg	unit
FAP22BM22609L-Code	MASHRABIYA	220 x 60 x 90	56/sqm	2,20 kg	500 u	1 100 kg	unit
FAP22BM22601L-Code	MASHRABIYA	220 x 60 x 105	56/sqm	2,42 kg	500 u	1 300 kg	unit
FAP22BM33509L-Code	MASHRABIYA	330 x 50 x 90	35/sqm	2,70 kg	350 u	945 kg	unit
FAP22BM33509Z-Code	Z-SHAPED MASHRABIYA	330 x 50 x 90	35/sqm	2,70 kg	350 u	945 kg	unit
FAP22BM33509H-Code	WAVES MASHRABIYA	330 x 50 x 90	35/sqm	2,70 kg	350 u	945 kg	unit
FAP22BM33509B-Code	B-SHAPED MASHRABIYA	330 x 50 x 90	35/sqm	2,70 kg	350 u	945 kg	unit
FAP22BM33509R-Code	ROUNDED MASHRABIYA	330 x 50 x 90	35/sqm	2,70 kg	350 u	945 kg	unit
FAP22PL216510-Code	POINTED	215 x 65 x 102	59/sqm	2,44 kg	387 u	945 kg	unit
FAP22HL226011-Code	WAVES	220 x 60 x 115	62/sqm	1,75 kg	546 u	956 kg	unit
FAP22BF22609B-Code	CONCAVE	220 x 60 x 90	62/sqm	2,50 kg	384 u	960 kg	unit
FAP22BF33509B-Code	CONCAVE	330 x 50 x 90	50/sqm	3,13 kg	300 u	939 kg	unit
FAP22BF22609A-Code	CONVEX	220 x 60 x 90	62/sqm	1,98 kg	500 u	990 kg	unit
FAP22BF33509A-Code	CONVEX	330 x 50 x 90	50/sqm	2,48 kg	300 u	900 kg	unit
FAP22BF22609D-Code	GROOVED	220 x 60 x 90	62/sqm	2,24 kg	500 u	1 120 kg	unit
FAP22BF33509D-Code	GROOVED	330 x 50 x 90	50/sqm	2,80 kg	350 u	980 kg	unit
FAP22BF22609C-Code	EMERGING	220 x 60 x 90	62/sqm	2,47 kg	400 u	988 kg	unit
FAP22BF33509C-Code	EMERGING	330 x 50 x 90	50/sqm	3,09 kg	300 u	927 kg	unit
GLAZED - 2 SIDES							
FAP22BL22609T-Code	STANDARD	220 x 60 x 90	62/sqm	2,3kg	500 u	1 150 kg	unit
FAP22BL22509T-Code	STANDARD	220 x 50 x 90	72/sqm	1,9kg	500 u	950 kg	unit
FAP22BL33509T-Code	STANDARD	330 x 50 x 90	50/sqm	2,85kg	350 u	998 kg	unit
FAP22BP33509T-Code	STANDARD	330 x 50 x 90	50/sqm	2,31 kg	400 u	924 kg	unit
FAP22BL22501T-Code	TRADITIONAL	220 x 50 x 105	72/sqm	2,125 kg	500 u	1 065 kg	unit
FAP22BN22501T-Code	PNA	220 x 50 x 105	72/sqm	1,77 kg	500 u	885 kg	unit
FAP22BL22601T-Code	TRADITIONAL	220 x 60 x 105	62/sqm	2,55 kg	500 u	1 275 kg	unit
FAP22BN22601T-Code	PNA	220 x 60 x 105	62/sqm	2,12 kg	500 u	1 060 kg	unit
FAP22BM22609LT-Code	MASHRABIYA	220 x 60 x 90	56/sqm	2,20 kg	500 u	1 100 kg	unit
FAP22BM22601LT-Code	MASHRABIYA	220 x 60 x 105	56/sqm	2,42 kg	500 u	1 300 kg	unit
FAP22BM33509LT-Code	MASHRABIYA	330 x 50 x 90	35/sqm	2,70 kg	350 u	1 080 kg	unit

Pallet 80 x 120 cm

ENGOBED, COLOURED TERRACOTTA - SMOOTH

REFERENCE	BRICK MODEL	FORMAT L x H x t / w in mm	NUMBER per sqm	WEIGHT /sqm or /u	QUANTITY sqm/pallet or u/pallet	WEIGHT in kg/pallet	SALES UNIT
GLAZED - 3 SIDES							
FAP22BL22609S-Code	STANDARD	220 x 60 x 90	62/sqm	2,3 kg	500 u	1 150 kg	unit
FAP22BL22509S-Code	STANDARD	220 x 50 x 90	72/sqm	1,9 kg	500 u	950 kg	unit
FAP22BL33509S-Code	STANDARD	330 x 50 x 90	50/sqm	2,85 kg	350 u	998 kg	unit
FAP22BP33509S-Code	STANDARD	330 x 50 x 90	50/sqm	2,31 kg	400 u	924 kg	unit
FAP22BL22501S-Code	TRADITIONAL	220 x 50 x 105	72/sqm	2,125 kg	500 u	1 065 kg	unit
FAP22BN22501S-Code	PNA	220 x 50 x 105	72/sqm	1,77 kg	500 u	885 kg	unit
FAP22BL22601S-Code	TRADITIONAL	220 x 60 x 105	62/sqm	2,55 kg	500 u	1 275 kg	unit
FAP22BN22601S-Code	PNA	220 x 60 x 105	62/sqm	2,12 kg	500 u	1 060 kg	unit
FAP22BM22609LS-Code	MASHRABIYA	220 x 60 x 90	56/sqm	2,20 kg	500 u	1 100 kg	unit
FAP22BM22601LS-Code	MASHRABIYA	220 x 60 x 105	56/sqm	2,42 kg	500 u	1 300 kg	unit
FAP22BM33509LS-Code	MASHRABIYA	330 x 50 x 90	35/sqm	2,70 kg	350 u	1 080 kg	unit

Pallet 80 x 120 cm



312 MontNoir



302 MontBlanc Mat



301 MontBlanc 17



307 MontGris 1



308 MontGris 2



309 MontGris 3



310 MontGris 4



311 MontGris 5



322 MontGris 6



304 MontBleu 7



305 MontBleu 8



321 MontBleu 9



323 MontVert



306 MontBrun



313 MontRouge



319 MontBeige



324 MontBeige 1



325 MontBeige 2



326 MontJaune



327 MontRose

ENGOBED, COLOURED TERRACOTTA - COLISEE

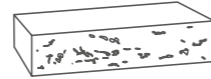

REFERENCE	BRICK MODEL	FORMAT L x H x t / w in mm	NUMBER per sqm	WEIGHT /sqm or /u	QUANTITY sqm/pallet or u/pallet	WEIGHT in kg/pallet	SALES UNIT
GLAZED - 1 SIDE							
FAP22BC226090-Code	STANDARD	220 x 60 x 90	62/sqm	2,3 kg	500 u	1 150 kg	unit
FAP22BC225090-Code	STANDARD	220 x 50 x 90	72/sqm	1,9 kg	500 u	950 kg	unit
FAP22BC335090-Code	STANDARD	330 x 50 x 90	50/sqm	2,85 kg	350 u	998 kg	unit
FAP22BP33509C-Code	STANDARD	330 x 50 x 90	50/sqm	2,31 kg	400 u	924 kg	unit
FAP22BC225010-Code	TRADITIONAL	220 x 50 x 105	72/sqm	2,125 kg	500 u	1 065 kg	unit
FAP22BN22501C-Code	PNA	220 x 50 x 105	72/sqm	1,77 kg	500 u	885 kg	unit
FAP22BC226010-Code	TRADITIONAL	220 x 60 x 105	62/sqm	2,55 kg	500 u	1 275 kg	unit
FAP22BN22601C-Code	PNA	220 x 60 x 105	62/sqm	2,12 kg	500 u	1 060 kg	unit
FAP22BM22609C-Code	MASHRABIYA	220 x 60 x 90	56/sqm	2,20 kg	500 u	1 100 kg	unit
FAP22BM22601C-Code	MASHRABIYA	220 x 60 x 105	56/sqm	2,42 kg	500 u	1 300 kg	unit
FAP22BM33509C-Code	MASHRABIYA	330 x 50 x 90	35/sqm	2,70 kg	350 u	1 080 kg	unit
GLAZED - 2 SIDES							
FAP22BC22609T-Code	STANDARD	220 x 60 x 90	62/sqm	2,3kg	500 u	1 150 kg	unit
FAP22BC22509T-Code	STANDARD	220 x 50 x 90	72/sqm	1,9kg	500 u	950 kg	unit
FAP22BC33509T-Code	STANDARD	330 x 50 x 90	50/sqm	2,85kg	350 u	998 kg	unit
FAP22BP33509CT-Code	STANDARD	330 x 50 x 90	50/sqm	2,31 kg	400 u	924 kg	unit
FAP22BC22501T-Code	TRADITIONAL	220 x 50 x 105	72/sqm	2,125 kg	500 u	1 065 kg	unit
FAP22BN22501CT-Code	PNA	220 x 50 x 105	72/sqm	1,77 kg	500 u	885 kg	unit
FAP22BC22601T-Code	TRADITIONAL	220 x 60 x 105	62/sqm	2,55 kg	500 u	1 275 kg	unit
FAP22BN22601CT-Code	PNA	220 x 60 x 105	62/sqm	2,12 kg	500 u	1 060 kg	unit
FAP22BM22609CT-Code	MASHRABIYA	220 x 60 x 90	56/sqm	2,20 kg	500 u	1 100 kg	unit
FAP22BM22601CT-Code	MASHRABIYA	220 x 60 x 105	56/sqm	2,42 kg	500 u	1 300 kg	unit
FAP22BM33509CT-Code	MASHRABIYA	330 x 50 x 90	35/sqm	2,70 kg	350 u	1 080 kg	unit
GLAZED - 3 SIDES							
FAP22BC22609S-Code	STANDARD	220 x 60 x 90	62/sqm	2,3kg	500 u	1 150 kg	unit
FAP22BC22509S-Code	STANDARD	220 x 50 x 90	72/sqm	1,9kg	500 u	950 kg	unit
FAP22BC33509S-Code	STANDARD	330 x 50 x 90	50/sqm	2,85kg	350 u	998 kg	unit
FAP22BP33509CS-Code	STANDARD	330 x 50 x 90	50/sqm	2,31 Kg	400 u	924 kg	unit
FAP22BC22501S-Code	TRADITIONAL	220 x 50 x 105	72/sqm	2,125 kg	500 u	1 065 kg	unit
FAP22BN22501CS-Code	PNA	220 x 50 x 105	72/sqm	1,77 kg	500 u	885 kg	unit
FAP22BC22601S-Code	TRADITIONAL	220 x 60 x 105	62/sqm	2,55 kg	500 u	1 275 kg	unit
FAP22BN22601CS-Code	PNA	220 x 60 x 105	62/sqm	2,12 kg	500 u	1 060 kg	unit
FAP22BM22609CS-Code	MASHRABIYA	220 x 60 x 90	56/sqm	2,20 kg	500 u	1 100 kg	unit
FAP22BM22601CS-Code	MASHRABIYA	220 x 60 x 105	56/sqm	2,42 kg	500 u	1 300 kg	unit
FAP22BM33509CS-Code	MASHRABIYA	330 x 50 x 90	35/sqm	2,70 kg	350 u	1 080 kg	unit

Pallet 80 x 120 cm



312 MontNoir



302 MontBlanc Mat



301 MontBlanc 17



307 MontGris 1



308 MontGris 2



309 MontGris 3



310 MontGris 4



311 MontGris 5



322 MontGris 6

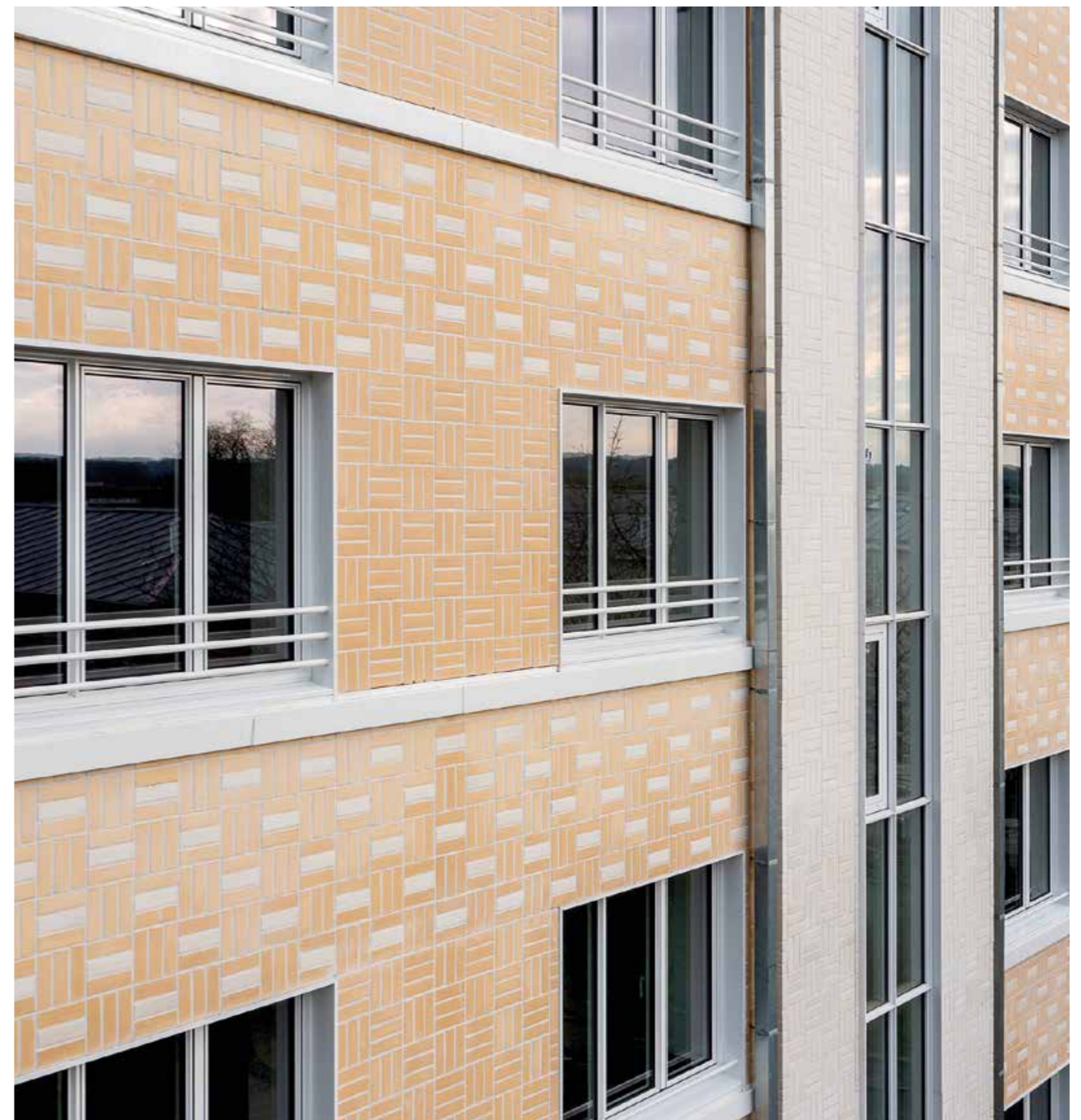

304 MontBleu 7



305 MontBleu 8



321 MontBleu 9



323 MontVert



306 MontBrun



313 MontRouge



319 MontBeige



324 MontBeige 1



325 MontBeige 2



326 MontJaune



327 MontRose

FLAMED NATURAL TERRACOTTA



REFERENCE	BRICK MODEL	FORMAT L x H x t / w in mm	NUMBER per sqm	WEIGHT /sqm or /u	QUANTITY sqm/pallet or u/pallet	WEIGHT in kg /pallet	SALES UNIT
FAP21BL225010-Code	TRADITIONAL	220 x 50 x 105	72/sqm	2,125 kg	500 u	1 065 kg	unit
FAP21BP225010-Code	PNA	220 x 50 x 105	72/sqm	1,77 kg	500 u	885 kg	unit
FAP21BL226010-Code	TRADITIONAL	220 x 60 x 105	62/sqm	2,55 kg	500 u	1 275 kg	unit
FAP21BP226010L-Code	PNA	220 x 60 x 105	62/sqm	2,12 kg	500 u	1 060 kg	unit
FAP21BL335090-Code	STANDARD	330 x 50 x 90	50/sqm	2,85 kg	350 u	998 kg	unit
FAP21BM22609L-Code	MASHRABIYA	220 x 60 x 90	56/sqm	2,20 kg	500 u	1 100 kg	unit
FAP21BM22601L-Code	MASHRABIYA	220 x 60 x 105	56/sqm	2,42 kg	500 u	1 300 kg	unit
FAP21BM335090-Code	MASHRABIYA	330 x 50 x 90	35/sqm	2,70 kg	350 u	1 080 kg	unit

Pallet 80 x 120 cm



208 Sologne



206 Sirius



221 Durtal



202 Chinon



219 Azay



222 Lucé



204 Orion



220 Valençay



HAND-MOULDED



Colour references:
see pages 28/31/32

REFERENCE	BRICK MODEL	FORMAT L x H x t / w in mm	NUMBER per sqm	WEIGHT /sqm or /u	QUANTITY sqm/pallet or u/pallet	WEIGHT in kg/pallet	SALES UNIT
FAP29BZ215010-Code	HAND-MOULDED & GLAZED	210 x 100 x 50	75/sqm	1,8 kg	500 u	900 kg	unit

BRUT DE FOUR

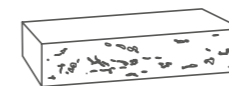

REFERENCE	BRICK MODEL	FORMAT L x H x t / w in mm	NUMBER per sqm	WEIGHT /sqm or /u	QUANTITY sqm/pallet or u/pallet	WEIGHT in kg /pallet	SALES UNIT
FAP25BF454090-Code	LONG	450 x 40 x 90	43/sqm	3,10 kg	350 u	1 085 kg	unit

Pallet 80 x 120 cm



623 Sahara 0



607 Sahara 3



624 Mali 0



610 Mali 2



622 Séquoia 0



603 Séquoia 3



625 Saturne 0



615 Saturne 1



620 Saturne 6

REMARQUABLES - STONWARE



NEW IN
2024

REFERENCE	BRICK MODEL	FORMAT L x H x t / w in mm	NUMBER per sqm	WEIGHT /sqm or /u	QUANTITY sqm/pallet or u/pallet	WEIGHT in kg /pallet	SALES UNIT
FAP32BE225090-Code	STANDARD	220 x 50 x 90	72/sqm	CU	CU	CU	unit
FAP31BE225090-Code	STANDARD	220 x 50 x 90	72/sqm	CU	CU	CU	unit

Pallet 80 x 120 cm



901 Merlot



902 Provence



903 Chenin



711 Merlot émail transparent



712 Provence émail transparent



713 Chenin émail transparent

SINGLE-FIRED GLAZING



REFERENCE	BRICK MODEL	FORMAT L x H x t / w in mm	NUMBER per sqm	WEIGHT /sqm or /u	QUANTITY sqm/pallet or u/pallet	WEIGHT in kg/pallet	SALES UNIT
GLAZED - 1 SIDE							
FAP29BL226090-Code	STANDARD	220 x 60 x 90	62/sqm	2,3 kg	500 u	1 150 kg	unit
FAP29BL225090-Code	STANDARD	220 x 50 x 90	72/sqm	1,9 kg	500 u	950 kg	unit
FAP29BL335090-Code	STANDARD	330 x 50 x 90	50/sqm	2,85 kg	350 u	998 kg	unit
FAP29BP335090-Code	STANDARD	330 x 50 x 90	50/sqm	2,31 kg	400 u	924 kg	unit
FAP29BL225010-Code	TRADITIONAL	220 x 50 x 105	72/sqm	2,125 kg	500 u	1 065 kg	unit
FAP29BN225010-Code	PNA	220 x 50 x 105	72/sqm	1,77 kg	500 u	885 kg	unit
FAP29BL226010-Code	TRADITIONAL	220 x 60 x 105	62/sqm	2,55 kg	500 u	1 275 kg	unit
FAP29BN226010-Code	PNA	220 x 60 x 105	62/sqm	2,12 kg	500 u	1 060 kg	unit
FAP29BM22609L-Code	MASHRABIYA	220 x 60 x 90	56/sqm	2,20 kg	500 u	1 100 kg	unit
FAP29BM22601L-Code	MASHRABIYA	220 x 60 x 105	56/sqm	2,42 kg	500 u	1 300 kg	unit
FAP29BM33509L-Code	MASHRABIYA	330 x 50 x 90	35/sqm	2,70 kg	350 u	1080 kg	unit
FAP29BM33509Z-Code	Z-SHAPED MASHRABIYA	330 x 50 x 90	35/sqm	2,70 kg	350 u	945 kg	unit
FAP29BM33509H-Code	WAVES MASHRABIYA	330 x 50 x 90	35/sqm	2,70 kg	350 u	945 kg	unit
FAP29BM33509B-Code	B-SHAPED MASHRABIYA	330 x 50 x 90	35/sqm	2,70 kg	350 u	945 kg	unit
FAP29BM33509R-Code	ROUNDED MASHRABIYA	330 x 50 x 90	35/sqm	2,70 kg	350 u	945 kg	unit
FAP29PL216510-Code	POINTED	215 x 65 x 102	59/sqm	2,44 kg	387 u	945 kg	unit
FAP29HL226011-Code	WAVES	220 x 60 x 115	62/sqm	1,75 kg	546 u	956 kg	unit
FAP29BF22609B-Code	CONCAVE	220 x 60 x 90	62/sqm	2,50 kg	384 u	960 kg	unit
FAP29BF33509B-Code	CONCAVE	330 x 50 x 90	50/sqm	3,13 kg	300 u	939 kg	unit
FAP29BF22609A-Code	CONVEX	220 x 60 x 90	62/sqm	1,98 kg	500 u	990 kg	unit
FAP29BF33509A-Code	CONVEX	330 x 50 x 90	50/sqm	2,48 kg	300 u	900 kg	unit
FAP29BF22609D-Code	GROOVED	220 x 60 x 90	62/sqm	2,24 kg	500 u	1 120 kg	unit
FAP29BF33509D-Code	GROOVED	330 x 50 x 90	50/sqm	2,80 kg	350 u	980 kg	unit
FAP29BF22609C-Code	EMERGING	220 x 60 x 90	62/sqm	2,47 kg	400 u	988 kg	unit
FAP29BF33509C-Code	EMERGING	330 x 50 x 90	50/sqm	3,09 kg	300 u	927 kg	unit
GLAZED - 2 SIDES							
FAP29BL22609T-Code	STANDARD	220 x 60 x 90	62/sqm	2,3 kg	500 u	1 150 kg	unit
FAP29BL22509T-Code	STANDARD	220 x 50 x 90	72/sqm	1,9 kg	500 u	950 kg	unit
FAP29BL33509T-Code	STANDARD	330 x 50 x 90	50/sqm	2,85 kg	350 u	998 kg	unit
FAP29BP33509T-Code	STANDARD	330 x 50 x 90	50/sqm	2,31 kg	400 u	924 kg	unit
FAP29BL22501T-Code	TRADITIONAL	220 x 50 x 105	72/sqm	2,125 kg	500 u	1 065 kg	unit
FAP29BN22501T-Code	PNA	220 x 50 x 105	72/sqm	1,77 kg	500 u	885 kg	unit
FAP29BL22601T-Code	TRADITIONAL	220 x 60 x 105	62/sqm	2,55 kg	500 u	1 275 kg	unit
FAP29BN22601T-Code	PNA	220 x 60 x 105	62/sqm	2,12 kg	500 u	1 060 kg	unit
FAP29BM22609LT-Code	MASHRABIYA	220 x 60 x 90	56/sqm	2,20 kg	500 u	1 100 kg	unit
FAP29BM22601LT-Code	MASHRABIYA	220 x 60 x 105	56/sqm	2,42 kg	500 u	1 300 kg	unit
FAP29BM3350LT-Code	MASHRABIYA	330 x 50 x 90	35/sqm	2,70 kg	350 u	1080 kg	unit

Pallet 80 x 120 cm

SINGLE-FIRED GLAZING

REFERENCE	BRICK MODEL	FORMAT L x H x t / w in mm	NUMBER per sqm	WEIGHT /sqm or /u	QUANTITY sqm/pallet or u/pallet	WEIGHT in kg/pallet	SALES UNIT
GLAZED - 3 SIDES							
FAP29BL22609S-Code	STANDARD	220 x 60 x 90	62/sqm	2,3 kg	500 u	1 150 kg	unit
FAP29BL22509S-Code	STANDARD	220 x 50 x 90	72/sqm	1,9 kg	500 u	950 kg	unit
FAP29BL33509S-Code	STANDARD	330 x 50 x 90	50/sqm	2,85 kg	350 u	998 kg	unit
FAP29BP33509S-Code	STANDARD	330 x 50 x 90	50/sqm	2,31 kg	400 u	924 kg	unit
FAP29BL22501S-Code	TRADITIONAL	220 x 50 x 105	72/sqm	2,125 kg	500 u	1 065 kg	unit
FAP29BN22501S-Code	PNA	220 x 50 x 105	72/sqm	1,77 kg	500 u	885 kg	unit
FAP29BL22601S-Code	TRADITIONAL	220 x 60 x 105	62/sqm	2,55 kg	500 u	1 275 kg	unit
FAP29BN22601S-Code	PNA	220 x 60 x 105	62/sqm	2,12 kg	500 u	1 060 kg	unit
FAP29BM22609LS-Code	MASHRABIYA	220 x 60 x 90	56/sqm	2,20 kg	500 u	1 100 kg	unit
FAP29BM22601LS-Code	MASHRABIYA	220 x 60 x 105	56/sqm	2,42 kg	500 u	1 300 kg	unit
FAP29BM3350LS-Code	MASHRABIYA	330 x 50 x 90	35/sqm	2,70 kg	350 u	1080 kg	unit

Pallet 80 x 120 cm



401 Blanc Satiné

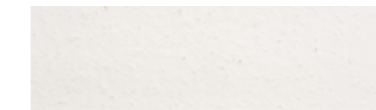

402 Blanc Mat



403 Blanc Brillant

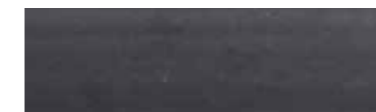

404 Gris 1



405 Gris 2

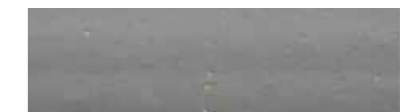

406 Gris 3



407 Gris 4



408 Gris 5



409 MonoRouge 1



410 MonoVert 5



411 MonoVert 6



412 MonoBleu 3



413 MonoJaune

TWICE-FIRED GLAZING



REFERENCE	BRICK MODEL	FORMAT L x H x t / w in mm	NUMBER per sqm	WEIGHT /sqm or /u	QUANTITY sqm/pallet or u/pallet	WEIGHT in kg/pallet	SALES UNIT
GLAZED - 1 SIDE							
FAP27BL225090-Code	STANDARD	220 x 60 x 90	62/sqm	2,3 kg	500 u	1 150 kg	unit
FAP27BL225090-Code	STANDARD	220 x 50 x 90	72/sqm	1,9 kg	500 u	950 kg	unit
FAP27BL335090-Code	STANDARD	330 x 50 x 90	50/sqm	2,85 kg	350 u	998 kg	unit
FAP27BP335090-Code	STANDARD	330 x 50 x 90	50/sqm	2,31 kg	400 u	924 kg	unit
FAP27BL225010-Code	TRADITIONAL	220 x 50 x 105	72/sqm	2,125 kg	500 u	1 065 kg	unit
FAP27BN225010-Code	PNA	220 x 50 x 105	72/sqm	1,77 kg	500 u	885 kg	unit
FAP27BL226010-Code	TRADITIONAL	220 x 60 x 105	62/sqm	2,55 kg	500 u	1 275 kg	unit
FAP27BN226010-Code	PNA	220 x 60 x 105	62/sqm	2,12 kg	500 u	1 060 kg	unit
FAP27BM22609L-Code	MASHRABIYA	220 x 60 x 90	56/sqm	2,20 kg	500 u	1 100 kg	unit
FAP27BM22601L-Code	MASHRABIYA	220 x 60 x 105	56/sqm	2,42 kg	500 u	1 300 kg	unit
FAP27BM33509L-Code	MASHRABIYA	330 x 50 x 90	35/sqm	2,70 kg	350 u	1080 kg	unit
FAP27BM33509Z-Code	Z-SHAPED MASHRABIYA	330 x 50 x 90	35/sqm	2,70 kg	350 u	945 kg	unit
FAP27BM33509H-Code	WAVES MASHRABIYA	330 x 50 x 90	35/sqm	2,70 kg	350 u	945 kg	unit
FAP27BM33509B-Code	B-SHAPED MASHRABIYA	330 x 50 x 90	35/sqm	2,70 kg	350 u	945 kg	unit
FAP27BM33509R-Code	ROUNDED MASHRABIYA	330 x 50 x 90	35/sqm	2,70 kg	350 u	945 kg	unit
FAP27PL216510-Code	POINTED	215 x 65 x 102	59/sqm	2,44 kg	387 u	945 kg	unit
FAP27HL226011-Code	WAVES	220 x 60 x 115	62/sqm	1,75 kg	546 u	956 kg	unit
FAP27BF22609B-Code	CONCAVE	220 x 60 x 90	62/sqm	2,50 kg	384 u	960 kg	unit
FAP27BF33509B-Code	CONCAVE	330 x 50 x 90	50/sqm	3,13 kg	300 u	939 kg	unit
FAP27BF22609A-Code	CONVEX	220 x 60 x 90	62/sqm	1,98 kg	500 u	990 kg	unit
FAP27BF33509A-Code	CONVEX	330 x 50 x 90	50/sqm	2,48 kg	300 u	900 kg	unit
FAP27BF22609D-Code	GROOVED	220 x 60 x 90	62/sqm	2,24 kg	500 u	1 120 kg	unit
FAP27BF33509D-Code	GROOVED	330 x 50 x 90	50/sqm	2,80 kg	350 u	980 kg	unit
FAP27BF22609C-Code	EMERGING	220 x 60 x 90	62/sqm	2,47 kg	400 u	988 kg	unit
FAP27BF33509C-Code	EMERGING	330 x 50 x 90	50/sqm	3,09 kg	300 u	927 kg	unit
GLAZED - 2 SIDES							
FAP27BL22609T-Code	STANDARD	220 x 60 x 90	62/sqm	2,3 kg	500 u	1 150 kg	unit
FAP27BL22509T-Code	STANDARD	220 x 50 x 90	72/sqm	1,9 kg	500 u	950 kg	unit
FAP27BL33509T-Code	STANDARD	330 x 50 x 90	50/sqm	2,85 kg	350 u	998 kg	unit
FAP27BP33509T-Code	STANDARD	330 x 50 x 90	50/sqm	2,31 kg	400 u	924 kg	unit
FAP27BL22501T-Code	TRADITIONAL	220 x 50 x 105	72/sqm	2,125 kg	500 u	1 065 kg	unit
FAP27BN22501T-Code	PNA	220 x 50 x 105	72/sqm	1,77 kg	500 u	885 kg	unit
FAP27BL22601T-Code	TRADITIONAL	220 x 60 x 105	62/sqm	2,55 kg	500 u	1 275 kg	unit
FAP27BN22601T-Code	PNA	220 x 60 x 105	62/sqm	2,12 kg	500 u	1 060 kg	unit
FAP27BM22609LT-Code	MASHRABIYA	220 x 60 x 90	56/sqm	2,20 kg	500 u	1 100 kg	unit
FAP27BM22601LT-Code	MASHRABIYA	220 x 60 x 105	56/sqm	2,42 kg	500 u	1 300 kg	unit
FAP27BM3350LT-Code	MASHRABIYA	330 x 50 x 90	35/sqm	2,70 kg	350 u	1080 kg	unit

Pallet 80 x 120 cm

TWICE-FIRED GLAZING

REFERENCE	BRICK MODEL	FORMAT L x H x t / w in mm	NUMBER per sqm	WEIGHT /sqm or /u	QUANTITY sqm/pallet or u/pallet	WEIGHT in kg/pallet	SALES UNIT
GLAZED - 3 SIDES							
FAP27BL22609S-Code	STANDARD	220 x 60 x 90	62/sqm	2,3 kg	500 u	1 150 kg	unit
FAP27BL22509S-Code	STANDARD	220 x 50 x 90	72/sqm	1,9 kg	500 u	950 kg	unit
FAP27BL33509S-Code	STANDARD	330 x 50 x 90	50/sqm	2,85 kg	350 u	998 kg	unit
FAP27BP33509S-Code	STANDARD	330 x 50 x 90	50/sqm	2,31 kg	400 u	924 kg	unit
FAP27BL22501S-Code	TRADITIONAL	220 x 50 x 105	72/sqm	2,125 kg	500 u	1 065 kg	unit
FAP27BN22501S-Code	PNA	220 x 50 x 105	72/sqm	1,77 kg	500 u	885 kg	unit
FAP27BL22601S-Code	TRADITIONAL	220 x 60 x 105	62/sqm	2,55 kg	500 u	1 275 kg	unit
FAP27BN22601S-Code	PNA	220 x 60 x 105	62/sqm	2,12 kg	500 u	1 060 kg	unit
FAP27BM22609LS-Code	MASHRABIYA	220 x 60 x 90	56/sqm	2,20 kg	500 u	1 100 kg	unit
FAP27BM22601LS-Code	MASHRABIYA	220 x 60 x 105	56/sqm	2,42 kg	500 u	1 300 kg	unit
FAP27BM3350LS-Code	MASHRABIYA	330 x 50 x 90	35/sqm	2,70 kg	350 u	1080 kg	unit

Pallet 80 x 120 cm

TRANSPARENT

535 Lumière	543 Silver	542 Titane	541 Havane
540 Régliste	536 Antarès	537 Montlouis	538 Montvaloir
		NEW IN 2024	
539 Médoc	116 Étain		

COLOUR

521 Noir	587 Gris 1	588 Gris 2	589 Gris 3
590 Gris 4	591 Gris 5	528 Vanille	511 Chatain
510 Cacao	505 Bleu 1	506 Bleu 2	507 Bleu 3
508 Bleu 4	514 Jaune	522 Orange	523 Rouge 1
524 Rouge 2	525 Rouge 3	526 Rouge 4	501 Aubergine 1
502 Aubergine 2	509 Brun	529 Vert 1	530 Vert 2
531 Vert 3	532 Vert 4	533 Vert 5	534 Vert 6
704 Beige 1	503 Blanc Brillant	504 Blanc Mat	

TWICE-FIRED GLAZING



REFERENCE	BRICK MODEL	FORMAT L x H x t / w in mm	NUMBER per sqm	WEIGHT /sqm or /u	QUANTITY sqm/pallet or u/pallet	WEIGHT in kg/pallet	SALES UNIT
GLAZED - 1 SIDE							
FAP27BL225090-Code	STANDARD	220 x 60 x 90	62/sqm	2,3 kg	500 u	1 150 kg	unit
FAP27BL225090-Code	STANDARD	220 x 50 x 90	72/sqm	1,9 kg	500 u	950 kg	unit
FAP27BL335090-Code	STANDARD	330 x 50 x 90	50/sqm	2,85 kg	350 u	998 kg	unit
FAP27BP335090-Code	STANDARD	330 x 50 x 90	50/sqm	2,31 kg	400 u	924 kg	unit
FAP27BL225010-Code	TRADITIONAL	220 x 50 x 105	72/sqm	2,125 kg	500 u	1 065 kg	unit
FAP27BN225010-Code	PNA	220 x 50 x 105	72/sqm	1,77 kg	500 u	885 kg	unit
FAP27BL226010-Code	TRADITIONAL	220 x 60 x 105	62/sqm	2,55 kg	500 u	1 275 kg	unit
FAP27BN226010-Code	PNA	220 x 60 x 105	62/sqm	2,12 kg	500 u	1 060 kg	unit
FAP27BM22609L-Code	MASHRABIYA	220 x 60 x 90	56/sqm	2,20 kg	500 u	1 100 kg	unit
FAP27BM22601L-Code	MASHRABIYA	220 x 60 x 105	56/sqm	2,42 kg	500 u	1 300 kg	unit
FAP27BM33509L-Code	MASHRABIYA	330 x 50 x 90	35/sqm	2,70 kg	350 u	1080 kg	unit
FAP27BM33509Z-Code	Z-SHAPED MASHRABIYA	330 x 50 x 90	35/sqm	2,70 kg	350 u	945 kg	unit
FAP27BM33509H-Code	WAVES MASHRABIYA	330 x 50 x 90	35/sqm	2,70 kg	350 u	945 kg	unit
FAP27BM33509B-Code	B-SHAPED MASHRABIYA	330 x 50 x 90	35/sqm	2,70 kg	350 u	945 kg	unit
FAP27BM33509R-Code	ROUNDED MASHRABIYA	330 x 50 x 90	35/sqm	2,70 kg	350 u	945 kg	unit
FAP27PL216510-Code	POINTED	215 x 65 x 102	59/sqm	2,44 kg	387 u	945 kg	unit
FAP27HL226011-Code	WAVES	220 x 60 x 115	62/sqm	1,75 kg	546 u	956 kg	unit
FAP27BF22609B-Code	CONCAVE	220 x 60 x 90	62/sqm	2,50 kg	384 u	960 kg	unit
FAP27BF33509B-Code	CONCAVE	330 x 50 x 90	50/sqm	3,13 kg	300 u	939 kg	unit
FAP27BF22609A-Code	CONVEX	220 x 60 x 90	62/sqm	1,98 kg	500 u	990 kg	unit
FAP27BF33509A-Code	CONVEX	330 x 50 x 90	50/sqm	2,48 kg	300 u	900 kg	unit
FAP27BF22609D-Code	GROOVED	220 x 60 x 90	62/sqm	2,24 kg	500 u	1 120 kg	unit
FAP27BF33509D-Code	GROOVED	330 x 50 x 90	50/sqm	2,80 kg	350 u	980 kg	unit
FAP27BF22609C-Code	EMERGING	220 x 60 x 90	62/sqm	2,47 kg	400 u	988 kg	unit
FAP27BF33509C-Code	EMERGING	330 x 50 x 90	50/sqm	3,09 kg	300 u	927 kg	unit
GLAZED - 2 SIDES							
FAP27BL22609T-Code	STANDARD	220 x 60 x 90	62/sqm	2,3 kg	500 u	1 150 kg	unit
FAP27BL22509T-Code	STANDARD	220 x 50 x 90	72/sqm	1,9 kg	500 u	950 kg	unit
FAP27BL33509T-Code	STANDARD	330 x 50 x 90	50/sqm	2,85 kg	350 u	998 kg	unit
FAP27BP33509T-Code	STANDARD	330 x 50 x 90	50/sqm	2,31 kg	400 u	924 kg	unit
FAP27BL22501T-Code	TRADITIONAL	220 x 50 x 105	72/sqm	2,125 kg	500 u	1 065 kg	unit
FAP27BN22501T-Code	PNA	220 x 50 x 105	72/sqm	1,77 kg	500 u	885 kg	unit
FAP27BL22601T-Code	TRADITIONAL	220 x 60 x 105	62/sqm	2,55 kg	500 u	1 275 kg	unit
FAP27BN22601T-Code	PNA	220 x 60 x 105	62/sqm	2,12 kg	500 u	1 060 kg	unit
FAP27BM22609LT-Code	MASHRABIYA	220 x 60 x 90	56/sqm	2,20 kg	500 u	1 100 kg	unit
FAP27BM22601LT-Code	MASHRABIYA	220 x 60 x 105	56/sqm	2,42 kg	500 u	1 300 kg	unit
FAP27BM3350LT-Code	MASHRABIYA	330 x 50 x 90	35/sqm	2,70 kg	350 u	1080 kg	unit

Pallet 80 x 120 cm

TWICE-FIRED GLAZING

REFERENCE	BRICK MODEL	FORMAT L x H x t / w in mm	NUMBER per sqm	WEIGHT /sqm or /u	QUANTITY sqm/pallet or u/pallet	WEIGHT in kg/pallet	SALES UNIT
GLAZED - 3 SIDES							
FAP27BL22609S-Code	STANDARD	220 x 60 x 90	62/sqm	2,3 kg	500 u	1 150 kg	unit
FAP27BL22509S-Code	STANDARD	220 x 50 x 90	72/sqm	1,9 kg	500 u	950 kg	unit
FAP27BL33509S-Code	STANDARD	330 x 50 x 90	50/sqm	2,85 kg	350 u	998 kg	unit
FAP27BP33509S-Code	STANDARD	330 x 50 x 90	50/sqm	2,31 kg	400 u	924 kg	unit
FAP27BL22501S-Code	TRADITIONAL	220 x 50 x 105	72/sqm	2,125 kg	500 u	1 065 kg	unit
FAP27BN22501S-Code	PNA	220 x 50 x 105	72/sqm	1,77 kg	500 u	885 kg	unit
FAP27BL22601S-Code	TRADITIONAL	220 x 60 x 105	62/sqm	2,55 kg	500 u	1 275 kg	unit
FAP27BN22601S-Code	PNA	220 x 60 x 105	62/sqm	2,12 kg	500 u	1 060 kg	unit
FAP27BM22609LS-Code	MASHRABIYA	220 x 60 x 90	56/sqm	2,20 kg	500 u	1 100 kg	unit
FAP27BM22601LS-Code	MASHRABIYA	220 x 60 x 105	56/sqm	2,42 kg	500 u	1 300 kg	unit
FAP27BM3350LS-Code	MASHRABIYA	330 x 50 x 90	35/sqm	2,70 kg	350 u	1080 kg	unit

Pallet 80 x 120 cm

CRYSTAL-CLEAR

544 Flanelle	545 Flanelle nuancé	564 Noyer	565 Noyer nuancé
548 Basalte	549 Basalte nuancé	566 Sureau	567 Sureau nuancé
550 Cosmos	551 Cosmos nuancé	568 Vert d'eau	569 Vert d'eau nuancé
552 Oxygène	553 Oxygène nuancé	570 Sapin	571 Sapin nuancé
554 Océan	555 Océan nuancé	572 Nénuphar	573 Nénuphar nuancé
556 Sable	557 Sable nuancé	574 Laurier	575 Laurier nuancé
558 Frêne	559 Frêne nuancé	576 Eucalyptus	577 Eucalyptus nuancé
560 Merisier	561 Merisier nuancé	578 Lagon	579 Lagon nuancé - α 0,66
562 Chêne	563 Chêne nuancé	701 Coquelicot	702 Coquelicot nuancé



METAL GLAZING



REFERENCE	BRICK MODEL	FORMAT L x H x t / w in mm	NUMBER per sqm	WEIGHT /sqm or /u	QUANTITY sqm/pallet or u/pallet	WEIGHT in kg/pallet	SALES UNIT
GLAZED - 1 SIDE							
FAP27BL225090-Code	STANDARD	220 x 60 x 90	62/sqm	2,3 kg	500 u	1 150 kg	unit
FAP27BL225090-Code	STANDARD	220 x 50 x 90	72/sqm	1,9 kg	500 u	950 kg	unit
FAP27BL335090-Code	STANDARD	330 x 50 x 90	50/sqm	2,85 kg	350 u	998 kg	unit
FAP27BP335090-Code	STANDARD	330 x 50 x 90	50/sqm	2,31 kg	400 u	924 kg	unit
FAP27BL225010-Code	TRADITIONAL	220 x 50 x 105	72/sqm	2,125 kg	500 u	1 065 kg	unit
FAP27BN225010-Code	PNA	220 x 50 x 105	72/sqm	1,77 kg	500 u	885 kg	unit
FAP27BL226010-Code	TRADITIONAL	220 x 60 x 105	62/sqm	2,55 kg	500 u	1 275 kg	unit
FAP27BN226010-Code	PNA	220 x 60 x 105	62/sqm	2,12 kg	500 u	1 060 kg	unit
FAP27BM22609L-Code	MASHRABIYA	220 x 60 x 90	56/sqm	2,20 kg	500 u	1 100 kg	unit
FAP27BM22601L-Code	MASHRABIYA	220 x 60 x 105	56/sqm	2,42 kg	500 u	1 300 kg	unit
FAP27BM33509L-Code	MASHRABIYA	330 x 50 x 90	35/sqm	2,70 kg	350 u	1080 kg	unit
FAP27BM33509Z-Code	Z-SHAPED MASHRABIYA	330 x 50 x 90	35/sqm	2,70 kg	350 u	945 kg	unit
FAP27BM33509H-Code	WAVES MASHRABIYA	330 x 50 x 90	35/sqm	2,70 kg	350 u	945 kg	unit
FAP27BM33509B-Code	B-SHAPED MASHRABIYA	330 x 50 x 90	35/sqm	2,70 kg	350 u	945 kg	unit
FAP27BM33509R-Code	ROUNDED MASHRABIYA	330 x 50 x 90	35/sqm	2,70 kg	350 u	945 kg	unit
FAP27PL216510-Code	POINTED	215 x 65 x 102	59/sqm	2,44 kg	387 u	945 kg	unit
FAP27HL226011-Code	WAVES	220 x 60 x 115	62m ²	1,75 kg	546 u	956 kg	unit
FAP27BF22609B-Code	CONCAVE	220 x 60 x 90	62/sqm	2,50 kg	384 u	960 kg	unit
FAP27BF33509B-Code	CONCAVE	330 x 50 x 90	50/sqm	3,13 kg	300 u	939 kg	unit
FAP27BF22609A-Code	CONVEX	220 x 60 x 90	62/sqm	1,98 kg	500 u	990 kg	unit
FAP27BF33509A-Code	CONVEX	330 x 50 x 90	50/sqm	2,48 kg	300 u	900 kg	unit
FAP27BF22609D-Code	GROOVED	220 x 60 x 90	62/sqm	2,24 kg	500 u	1 120 kg	unit
FAP27BF33509D-Code	GROOVED	330 x 50 x 90	50/sqm	2,80 kg	350 u	980 kg	unit
FAP27BF22609C-Code	EMERGING	220 x 60 x 90	62/sqm	2,47 kg	400 u	988 kg	unit
FAP27BF33509C-Code	EMERGING	330 x 50 x 90	50/sqm	3,09 kg	300 u	927 kg	unit
GLAZED - 2 SIDES							
FAP27BL22609T-Code	STANDARD	220 x 60 x 90	62/sqm	2,3 kg	500 u	1 150 kg	unit
FAP27BL22509T-Code	STANDARD	220 x 50 x 90	72/sqm	1,9 kg	500 u	950 kg	unit
FAP27BL33509T-Code	STANDARD	330 x 50 x 90	50/sqm	2,85 kg	350 u	998 kg	unit
FAP27BP33509T-Code	STANDARD	330 x 50 x 90	50/sqm	2,31 kg	400 u	924 kg	unit
FAP27BL22501T-Code	TRADITIONAL	220 x 50 x 105	72/sqm	2,125 kg	500 u	1 065 kg	unit
FAP27BN22501T-Code	PNA	220 x 50 x 105	72/sqm	1,77 kg	500 u	885 kg	unit
FAP27BL22601T-Code	TRADITIONAL	220 x 60 x 105	62/sqm	2,55 kg	500 u	1 275 kg	unit
FAP27BN22601T-Code	PNA	220 x 60 x 105	62/sqm	2,12 kg	500 u	1 060 kg	unit
FAP27BM22609LT-Code	MASHRABIYA	220 x 60 x 90	56/sqm	2,20 kg	500 u	1 100 kg	unit
FAP27BM22601LT-Code	MASHRABIYA	220 x 60 x 105	56/sqm	2,42 kg	500 u	1 300 kg	unit
FAP27BM3350LT-Code	MASHRABIYA	330 x 50 x 90	35/sqm	2,70 kg	350 u	1080 kg	unit

Pallet 80 x 120 cm

METAL GLAZING

REFERENCE	BRICK MODEL	FORMAT L x H x t / w in mm	NUMBER per sqm	WEIGHT /sqm or /u	QUANTITY sqm/pallet or u/pallet	WEIGHT in kg/pallet	SALES UNIT
GLAZED - 3 SIDES							
FAP27BL22609S-Code	STANDARD	220 x 60 x 90	62/sqm	2,3 kg	500 u	1 150 kg	unit
FAP27BL22509S-Code	STANDARD	220 x 50 x 90	72/sqm	1,9 kg	500 u	950 kg	unit
FAP27BL33509S-Code	STANDARD	330 x 50 x 90	50/sqm	2,85 kg	350 u	998 kg	unit
FAP27BP33509S-Code	STANDARD	330 x 50 x 90	50/sqm	2,31 kg	400 u	924 kg	unit
FAP27BL22501S-Code	TRADITIONAL	220 x 50 x 105	72/sqm	2,125 kg	500 u	1 065 kg	unit
FAP27BN22501S-Code	PNA	220 x 50 x 105	72/sqm	1,77 kg	500 u	885 kg	unit
FAP27BL22601S-Code	TRADITIONAL	220 x 60 x 105	62/sqm	2,55 kg	500 u	1 275 kg	unit
FAP27BN22601S-Code	PNA	220 x 60 x 105	62/sqm	2,12 kg	500 u	1 060 kg	unit
FAP27BM22609LS-Code	MASHRABIYA	220 x 60 x 90	56/sqm	2,20 kg	500 u	1 100 kg	unit
FAP27BM22601LS-Code	MASHRABIYA	220 x 60 x 105	56/sqm	2,42 kg	500 u	1 300 kg	unit
FAP27BM3350LS-Code	MASHRABIYA	330 x 50 x 90	35/sqm	2,70 kg	350 u	1080 kg	unit

Pallet 80 x 120 cm



516 Fabula



517 Légende



520 Utopie



518 Mirage



515 Cuivre



519 Or



592 Doré



593 Argenté

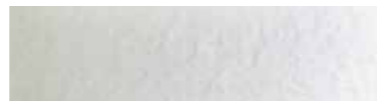

594 Irisé

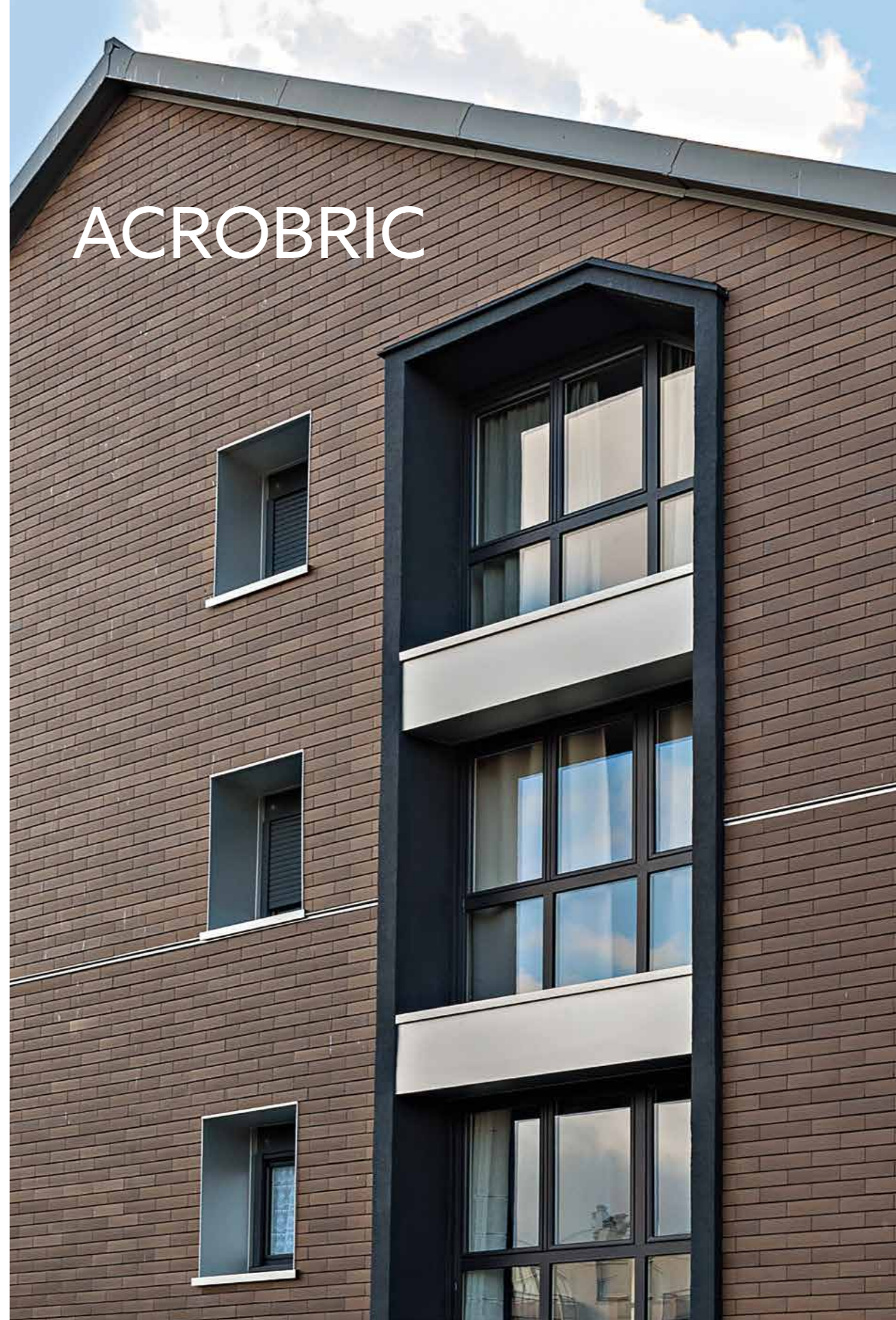

ACROBRIC

TILES

PAVING STONES

SCREEN WALLS

GENERAL SALESTERMS
AND CONDITIONS

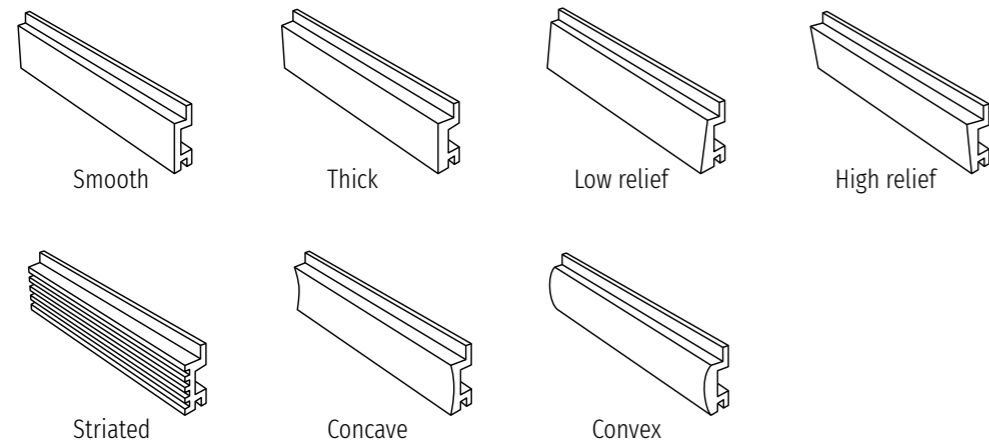

NATURAL TERRACOTTA



Colour references: see page 15

REFERENCE	ACROBRIC MODEL	FORMAT L x w x H in mm (overall dimensions 110)	NUMBER per sqm	WEIGHT /sqm	QUANTITY sqm/pallet	WEIGHT in kg /pallet	SALES UNIT
FAP20PA349035-Code	STRAIGHT	330 x 90 x 35	31/sqm	30 kg	27 sqm	810 kg	sqm
FAP20PS349035-Code	STRIATED	330 x 90 x 35	31/sqm	39 kg	27 sqm	1 053 kg	sqm
FAP20PB349035-Code	LOW RELIEF	330 x 90 x 35	31/sqm	36 kg	27 sqm	1 332 kg	sqm
FAP20PH349035-Code	HIGH RELIEF	330 x 90 x 35	31/sqm	36 kg	27 sqm	972 kg	sqm
FAP20PE349035-Code	THICK	330 x 90 x 35	31/sqm	42 kg	27 sqm	1 134 kg	sqm
FAP20PY349035-Code	CONVEX	330 x 90 x 35	31/sqm	36 kg	27 sqm	972 kg	sqm
FAP20PZ349035-Code	CONCAVE	330 x 90 x 35	31/sqm	36 kg	27 sqm	972 kg	sqm
	Wooden BRACKET treated grade III	Trapézoïdal angle 60° 4.2 m	10/sqm	CU	CU	CU	lm

CU = Contact Us

ENGOBED, COLOURED TERRACOTTA



Colour references: see page 21

REFERENCE	ACROBRIC MODEL	FORMAT L x w x H in mm (overall dimensions 110)	NUMBER per sqm	WEIGHT /sqm	QUANTITY sqm/pallet	WEIGHT in kg /pallet	SALES UNIT
FAP22PA349035-Code	STRAIGHT	330 x 90 x 35	31/sqm	30 kg	27 sqm	810 kg	sqm
FAP22PB349035-Code	LOW RELIEF	330 x 90 x 35	31/sqm	36 kg	27 sqm	1 332 kg	sqm
FAP22PH349035-Code	HIGH RELIEF	330 x 90 x 35	31/sqm	36 kg	27 sqm	972 kg	sqm
FAP22PE349035-Code	THICK	330 x 90 x 35	31/sqm	42 kg	27 sqm	1 134 kg	sqm
FAP22PY349035-Code	CONVEX	330 x 90 x 35	31/sqm	36 kg	27 sqm	972 kg	sqm
FAP22PZ349035-Code	CONCAVE	330 x 90 x 35	31/sqm	36 kg	27 sqm	972 kg	sqm
	Wooden BRACKET treated grade III	Trapézoïdal angle 60° 4.2 m	10/sqm	CU	CU	CU	lm

CU = Contact Us

TRAPEZOIDAL WOODEN BRACKET - DIAGRAM

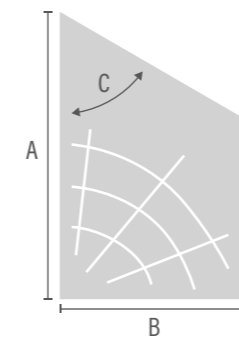

Marks	Dimensions	Tolerances
A	38 mm	± 1 mm
B	25 mm	± 1 mm
C	60 °	± 5°
Max. width maxi	3 000	± 100 mm
Quality	EN 335 standard	-

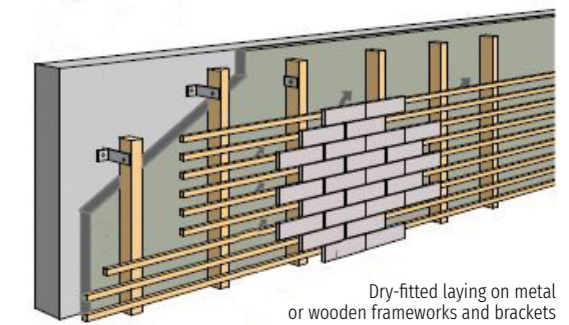

Dry-fitted laying on metal or wooden frameworks and brackets

SINGLE-FIRED GLAZING



Colour references: see page 28

REFERENCE	ACROBRIC MODEL	FORMAT L x w x H in mm (overall dimensions 110)	NUMBER per sqm	WEIGHT /sqm	QUANTITY sqm/pallet	WEIGHT in kg /pallet	SALES UNIT
FAP29PA349035-Code	STRAIGHT	330 x 90 x 35	31/sqm	30 kg	27 sqm	810 kg	sqm
FAP29PB349035-Code	LOW RELIEF	330 x 90 x 35	31/sqm	36 kg	27 sqm	1 332 kg	sqm
FAP29PH349035-Code	HIGH RELIEF	330 x 90 x 35	31/sqm	36 kg	27 sqm	972 kg	sqm
FAP29PE349035-Code	THICK	330 x 90 x 35	31/sqm	42 kg	27 sqm	1 134 kg	sqm
FAP29PY349035-Code	CONVEX	330 x 90 x 35	31/sqm	36 kg	27 sqm	972 kg	sqm
FAP29PZ349035-Code	CONCAVE	330 x 90 x 35	31/sqm	36 kg	27 sqm	972 kg	sqm
	Wooden BRACKET treated grade III	Trapézoïdal angle 60° 4.2 m	10/sqm	CU	CU	CU	lm

CU = Contact Us

TWICE-FIRED GLAZING



Colour references: see page 29/31

REFERENCE	ACROBRIC MODEL	FORMAT L x w x H in mm (overall dimensions 110)	NUMBER per sqm	WEIGHT /sqm	QUANTITY sqm/pallet	WEIGHT in kg /pallet	SALES UNIT
FAP27PA349035-Code	STRAIGHT	330 x 90 x 35	31/sqm	30 kg	27 sqm	810 kg	sqm
FAP27PS349035-Code	STRIATED	330 x 90 x 35	31/sqm	39 kg	27 sqm	1 053 kg	sqm
FAP27PB349035-Code	LOW RELIEF	330 x 90 x 35	31/sqm	36 kg	27 sqm	1 332 kg	sqm
FAP27PH349035-Code	HIGH RELIEF	330 x 90 x 35	31/sqm	36 kg	27 sqm	972 kg	sqm
FAP27PE349035-Code	THICK	330 x 90 x 35	31/sqm	42 kg	27 sqm	1 134 kg	sqm
FAP27PY349035-Code	CONVEX	330 x 90 x 35	31/sqm	36 kg	27 sqm	972 kg	sqm
FAP27PZ349035-Code	CONCAVE	330 x 90 x 35	31/sqm	36 kg	27 sqm	972 kg	sqm
	Wooden BRACKET treated grade III	Trapézoïdal angle 60° 4.2 m	10/sqm	CU	CU	CU	lm

CU = Contact Us



METAL GLAZING



Colour references: see page 32

REFERENCE	ACROBRIC MODEL	FORMAT L x w x H in mm (overall dimensions 110)	NUMBER per sqm	WEIGHT /sqm	QUANTITY sqm/pallet	WEIGHT in kg /pallet	SALES UNIT
FAP27PA349035-Code	STRAIGHT	330 x 90 x 35	31/sqm	30 kg	27 sqm	810 kg	sqm
FAP27PS349035-Code	STRIATED	330 x 90 x 35	31/sqm	39 kg	27 sqm	1 053 kg	sqm
FAP27PB349035-Code	LOW RELIEF	330 x 90 x 35	31/sqm	36 kg	27 sqm	1 332 kg	sqm
FAP27PH349035-Code	HIGH RELIEF	330 x 90 x 35	31/sqm	36 kg	27 sqm	972 kg	sqm
FAP27PE349035-Code	THICK	330 x 90 x 35	31/sqm	42 kg	27 sqm	1 134 kg	sqm
FAP27PY349035-Code	CONVEX	330 x 90 x 35	31/sqm	36 kg	27 sqm	972 kg	sqm
FAP27PZ349035-Code	CONCAVE	330 x 90 x 35	31/sqm	36 kg	27 sqm	972 kg	sqm
	Wooden BRACKET treated grade III	Trapézoïdal angle 60° 4.2 m	10/sqm	CU	CU	CU	lm

CU = Contact Us



TILES

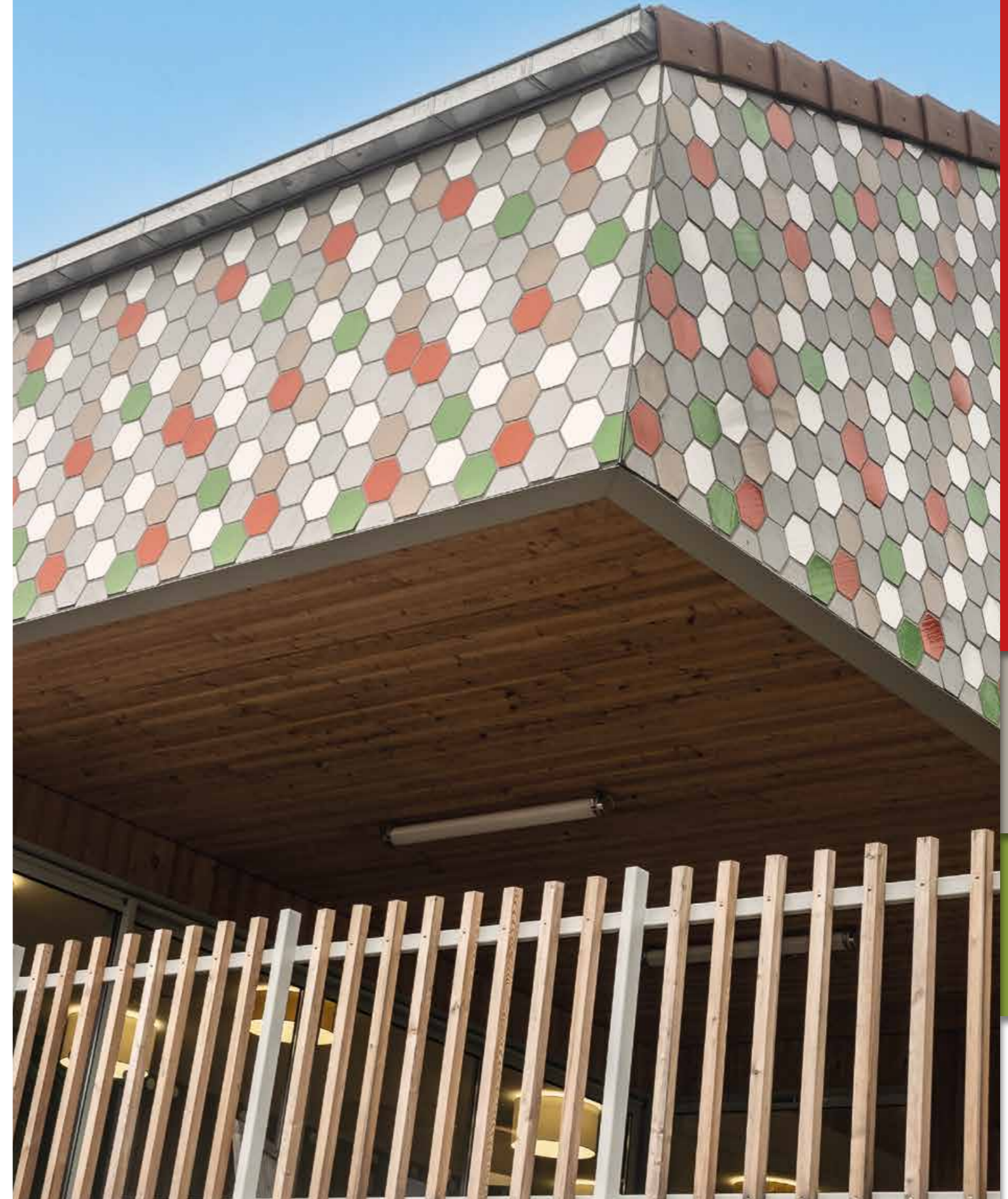

TILES

PAVING STONES

SCREEN WALLS

GENERAL SALESTERMS
AND CONDITIONS

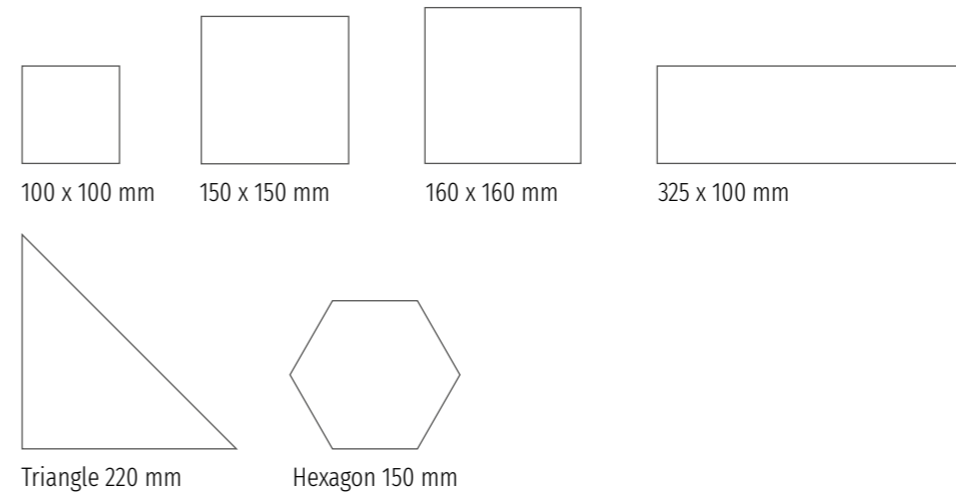
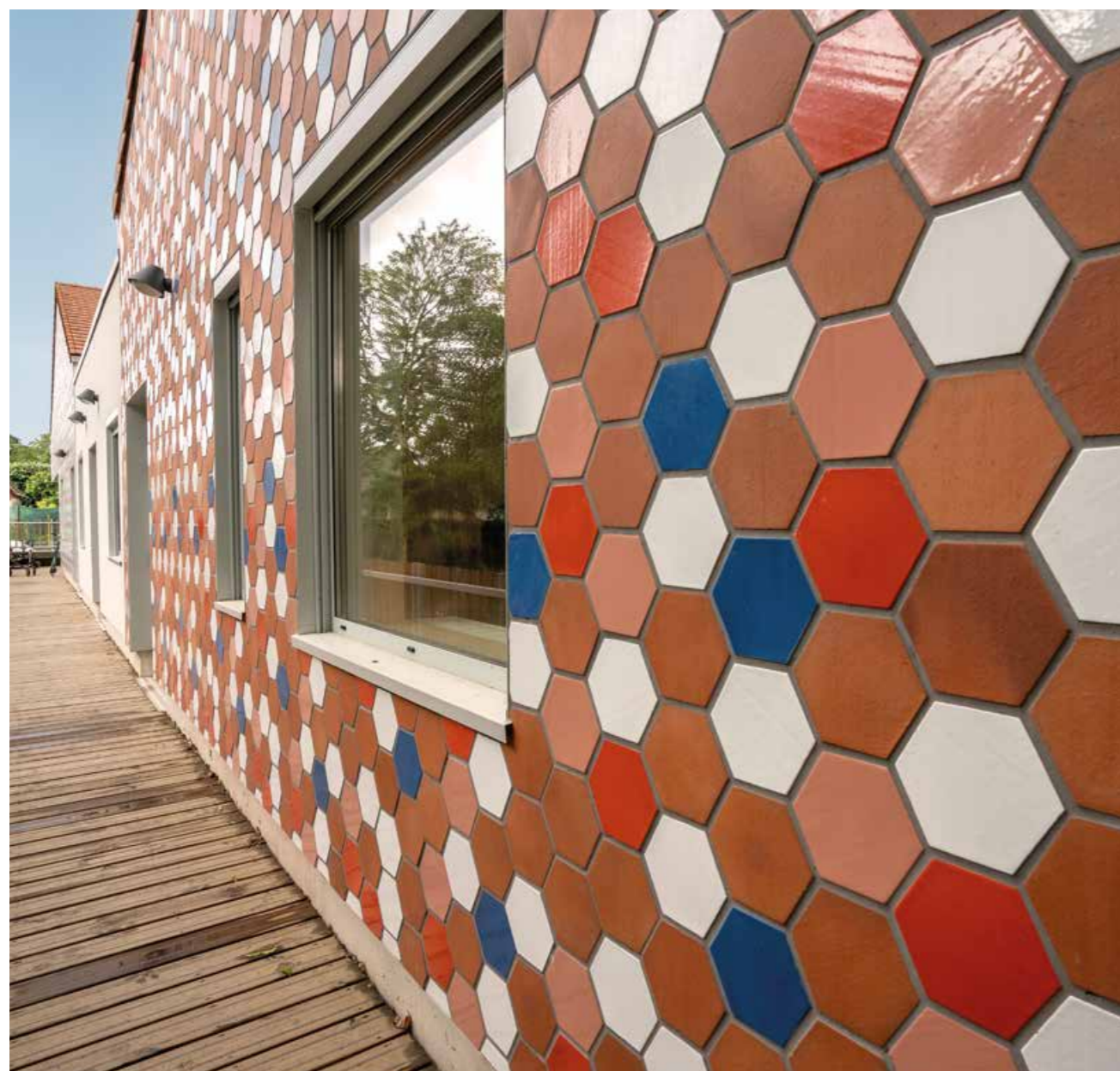
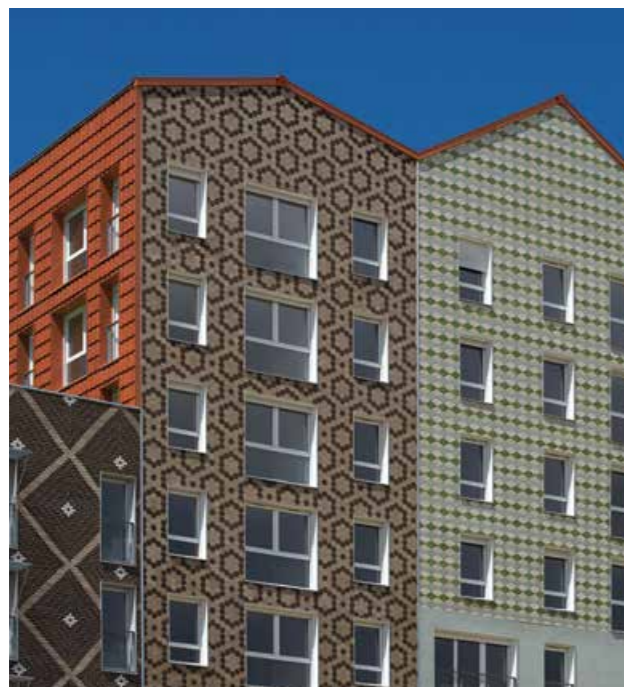

NATURAL TERRACOTTA



Colour references: see page 15

REFERENCE	TILE MODEL	FORMAT L x w x H in mm	NUMBER /sqm	WEIGHT /unit	INDICATIVE QUANTITY		WEIGHT in kg /pallet	SALES UNIT
					u/box	sqm/pallet or u/pallet		
FAS20CL161613-Code	TILE 160	160 x 160 x 13	35	0,67 kg	19 u	32 sqm	750 kg	sqm
FAS20CL101011-Code	TILE 100	100 x 100 x 11	82	0,25 kg	56 u	41 sqm	841 kg	sqm
FAS20CL321013-Code	RECTANGULAR	325 x 100 x 13	27	0,850 kg	22 u	40 sqm	940 kg	sqm
FAS20TL222213-Code	TRIANGLE 220	220 x 13	16	1,25 kg	13 u	780 u	975 kg	unit
FAS20HL151513-Code	HEXAGON 150	150 x 13	50	0,52 kg	20 u	24 sqm	624 kg	sqm

ENGOBED, COLOURED TERRACOTTA



Colour references: see page 21

REFERENCE	TILE MODEL	FORMAT L x w x H in mm	NUMBER /sqm	WEIGHT /unit	INDICATIVE QUANTITY		WEIGHT in kg /pallet	SALES UNIT
					u/box	sqm/pallet or u/pallet		
FAS22CL151513-Code	TILE 150	150 x 150 x 13	39	0,59 kg	20 u	25 sqm	590 kg	sqm
FAS22CL101011-Code	TILE 100	100 x 100 x 11	82	0,25 kg	56 u	41 sqm	841 kg	sqm
FAS22CL321013-Code	RECTANGULAR	325 x 100 x 13	27	0,850 kg	22 u	40 sqm	940 kg	sqm
FAS22TL222213-Code	TRIANGLE 220	220 x 13	16	1,25 kg	13 u	780 u	975 kg	unit
FAS22HL151513-Code	HEXAGON 150	150 x 13	50	0,52 kg	20 u	24 sqm	624 kg	sqm



PAVING STONES

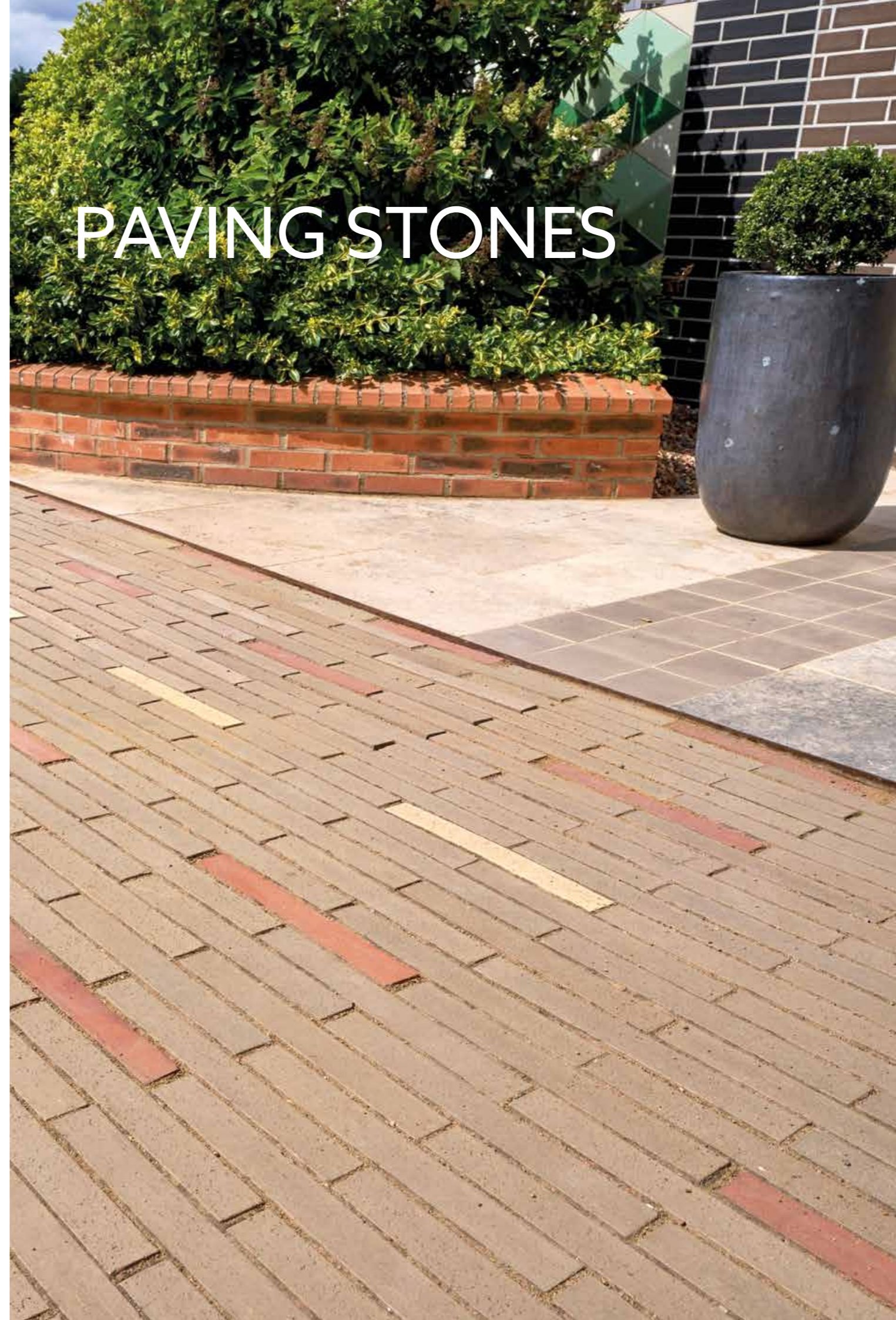

TWICE-FIRED GLAZING



Colour references: see page 29/31

REFERENCE	TILE MODEL	FORMAT L x w x H in mm	NUMBER /sqm	WEIGHT /unit	INDICATIVE QUANTITY		WEIGHT in kg /pallet	SALES UNIT
					u/box	sqm/pallet or u/pallet		
FAS27CL151513-Code	TILE 150	150 x 150 x 13	39	0,59 kg	20 u	25 sqm	590 kg	sqm
FAS27CL101011-Code	TILE 100	100 x 100 x 11	82	0,25 kg	56 u	41 sqm	841 kg	sqm
FAS27CL321013-Code	RECTANGULAR	325 x 100 x 13	27	0,850 kg	22 u	40 sqm	940 kg	sqm
FAS27TL222213-Code	TRIANGLE 220	220 x 13	16	1,25 kg	13 u	780 u	975 kg	unit
FAS27HL151513-Code	HEXAGON 150	150 x 13	50	0,52 kg	20 u	24 sqm	624 kg	sqm

METAL GLAZING



Colour references: see page 32

REFERENCE	TILE MODEL	FORMAT L x w x H in mm	NUMBER /sqm	WEIGHT /unit	INDICATIVE QUANTITY		WEIGHT in kg /pallet	SALES UNIT
					u/box	sqm/pallet or u/pallet		
FAS27CL151513-Code	TILE 150	150 x 150 x 13	39	0,59 kg	20 u	25 sqm	590 kg	sqm
FAS27CL101011-Code	TILE 100	100 x 100 x 11	82	0,25 kg	56 u	41 sqm	841 kg	sqm
FAS27CL321013-Code	RECTANGULAR	325 x 100 x 13	27	0,850 kg	22 u	40 sqm	940 kg	sqm
FAS27TL222213-Code	TRIANGLE 220	220 x 13	16	1,25 kg	13 u	780 u	975 kg	unit
FAS27HL151513-Code	HEXAGON 150	150 x 13	50	0,52 kg	20 u	24 sqm	624 kg	sqm

PAVING STONES

SCREEN WALLS

GENERAL SALESTERMS
AND CONDITIONS



Ecurie paving stone

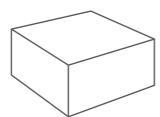

Terrasse paving stone

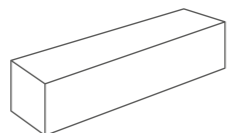

Long paving stone

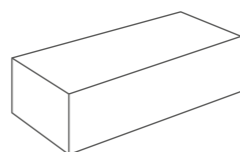

Smooth paving stone

NATURAL TERRACOTTA

REFERENCE	PAVING STONE MODEL	FORMAT L x w x H in mm	NUMBER /sqm	WEIGHT /sqm	INDICATIVE QUANTITY		WEIGHT in kg/pallet	SALES UNIT
					u/box	sqm/pallet or u/pallet		
FAP20PV101040-Code	TERRASSE	105 x 105 x 40	90	74 kg	Bulk	837 u	850 kg	sqm
FAP20PE212122-Code	ECURIE	210 x 210 x 22	24	51 kg	Bulk	20 sqm	1 020 kg	sqm
FAP20PB224040-Code	LONG	220 x 40 x 40	87	113 kg	Bulk	900 u	1170 kg	sqm
FAP20PB334040-Code	LONG	330 x 40 x 40	59	118 kg	Bulk	560 u	1120 kg	sqm

* Sqm = with 10 mm joint

Pallet 80 x 120 cm



103 Azay



108 Durtal



109 Valençay



105 Montfort



112 Sologne



203 Lynx

ORIGINELLE

REFERENCE	PAVING STONE MODEL	FORMAT L x w x H in mm	NUMBER /sqm	WEIGHT /sqm	INDICATIVE QUANTITY		WEIGHT in kg/pallet	SALES UNIT
					u/box	sqm/pallet or u/pallet		
FAP21BL225010-Code	SMOOTH	220 x 50 x 105 Face visible 220 x 105	82	2,13 kg	Bulk	500 u	1 065 kg	unit

* Sqm = with 10 mm joint

Pallet 80 x 120 cm



219 Azay



220 Valençay



221 Durtal



222 Lucé

SCREEN WALLS





Poisson (Fish)



Tramontane



Carré

NATURAL TERRACOTTA

REFERENCE	SCREEN WALL MODEL	FORMAT L x w x H in mm	NUMBER /sqm	WEIGHT /unit	INDICATIVE QUANTITY		WEIGHT in kg/pallet	SALES UNIT
					u/box	u/pallet		
FAA20CP282890-Code	POISSON	280 x 280 x 90	13/sqm (3,6/lm)	4,5 kg	Bulk	96 u	450 kg	unit
FAA20CT202090-Code	TRAMONTANE	200 x 200 x 90	25/sqm (5/lm)	2,5 kg	Bulk	125 u	330 kg	unit
FAA20CC202090-Code	CARRÉ	200 x 200 x 90	25/sqm (5/lm)	2 kg	Bulk	125 u	250 kg	unit

Pallet 80 x 120 cm



103 Azay



108 Durtal



109 Valençay



105 Montfort



112 Sologne



GENERAL SALES TERMS AND CONDITIONS

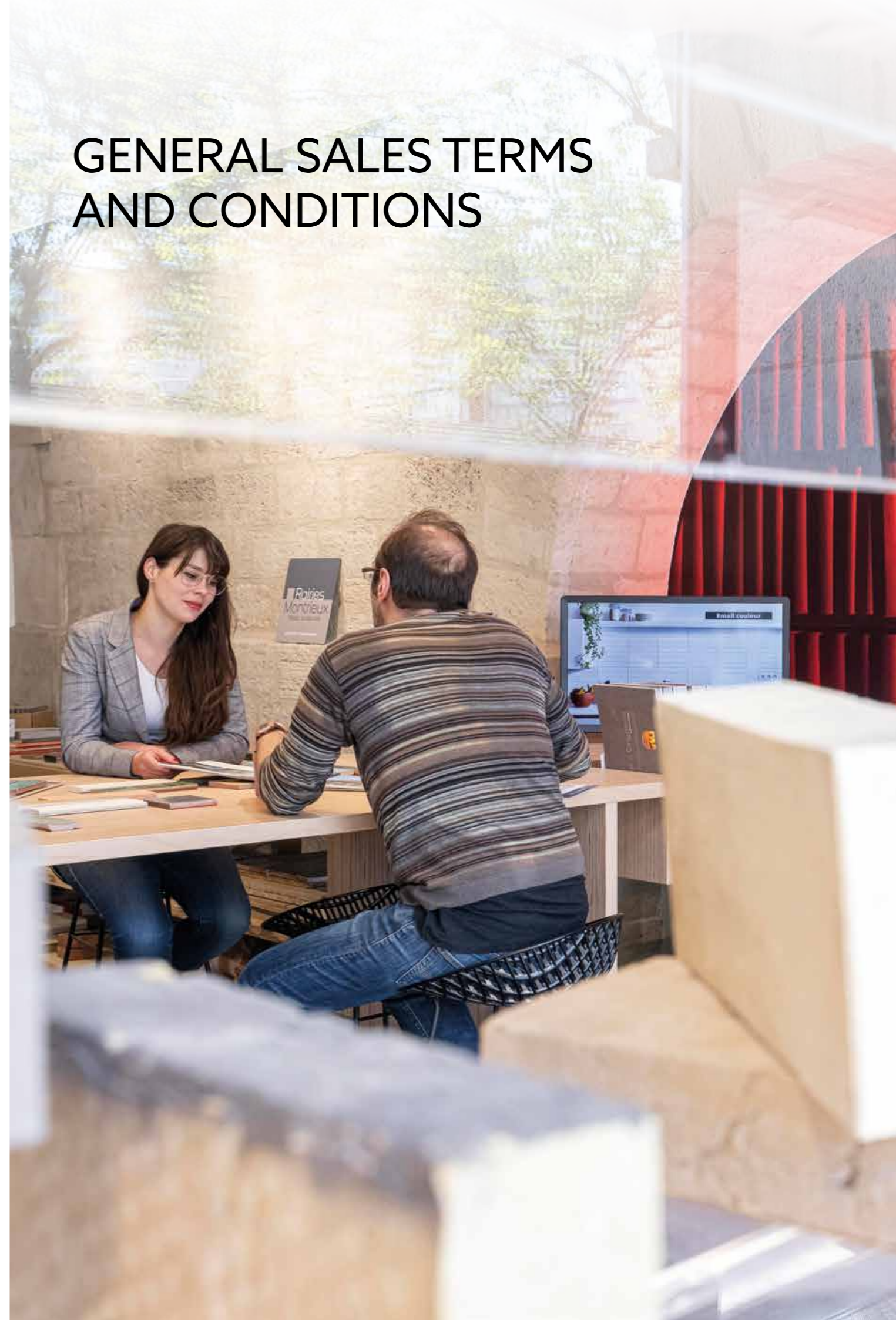

GENERAL SALES TERMS AND CONDITIONS

GENERAL PROVISIONS

Any order implies that the Buyer accepts the Terms and Conditions hereof as well as our pricing conditions ipso jure. They shall prevail over any other contrary provisions stipulated by the Buyer in particular in their own Terms and Conditions or purchase orders.

The fact that the seller doesn't make use of one of the Terms and Conditions hereby at some point shall not be interpreted as a waiver to exercise one of these Terms and Conditions at a later date. The distributors of our products shall make our Terms and Conditions enforceable against any subsequent purchaser regarding the provisions with which they are concerned.

CONTRACTUAL DOCUMENTS – ORDERS

All orders are subject to our prior consent further to which the order will be either acknowledged or directly executed. All orders shall include the information necessary to be executed properly. Any modification or resolution of order required by the Buyer shall be taken into account only if it is notified in writing before the products have been shipped for those included in the catalogue, or before production begins for orders of custom-made products previously accepted by us and subject to a down payment. In case an order is cancelled, any down payment already paid shall be subject to a credit note.

Our price lists, catalogues or any other promotional documents shall not constitute an offer. We reserve the right to remove a product without any prior notice or to modify its characteristics in particular for technical reasons or modifications of our manufacturing conditions.

Price offers are established free of charge and imply no obligation from us. They are null and void ipso jure after a period of 3 months in the absence of a definitive order within this period. Any order requiring a specific production (products not included in the catalogue or price list) cannot be cancelled.

LEAD TIMES

Manufacturing and delivery lead times are given for information only with no other obligation from our company. The availability of our products is given unless sales are confirmed meanwhile. Delays shall not result in claims or order cancellation. We shall not be held liable in the event of force majeure or other circumstances beyond our control (strikes, frost, fires, shortages...). Failure by the Buyer to comply with our terms of payment in respect of previous or current deliveries shall release our company from any commitment or liability.

RELEASE / AVAILABILITY OF PRODUCTS

The goods are sold « in our factories » or « in our warehouses » where they are approved by the Buyer once and for all without having to ask them. Loading and transport risks are thus transferred to the Buyer who is held liable for taking delivery of the goods once available and ready for loading even if they were sold « free of charge ».

TRANSPORT – DELIVERY

Deliveries are made "Free Carrier" (FCA) to the warehouses or registered offices of Rairies Montrieux. The agreed delivery terms will always be interpreted in accordance with the Incoterms® in force at the time of the conclusion of the contract between Rairies Montrieux and the Buyer.

The Buyer is obliged to arrange the collection of the goods at the agreed address and time.

In addition, without prejudice to its other rights under the law and the contract, Rairies Montrieux is also entitled to store the goods or have them stored at the Buyer's expense and risk, without notice of default being required, and to invoice the Buyer for the costs incurred. In this case, the Buyer may not refuse payment on the grounds that delivery has not taken place. If, as a result of force majeure, Rairies Montrieux is prevented from delivering or delivering in the normal way, it is entitled to extend the delivery period by the duration of the force majeure.

Consequently, a delay in delivery does not release the Buyer from his obligation to accept or pay for the goods and/or services.

RECEPTION – TOLERANCES

Our products travel at the recipient's risk regardless the mode of transport. It is for the client to check the condition and quantity of our products upon delivery and in case of damage or missing quantities, to carry out all the legal procedures as defined in the article L133-3 of the French commercial code within three days, in order to protect one's rights against carriers. Be aware: the statement « subject to unpacking » has no legal value. In case of lack of clear reservations on the delivery slip, the goods shall be considered compliant with the delivery. All our products are sold respecting the customary tolerances for ceramic products in terms of colour, thickness, length, etc. Our responsibility shall not be questioned for these reasons. It is the same for sizes of specific articles that are made in the best possible conditions for which, however, we cannot guarantee the execution to the exact required dimensions.

PRICES

Our prices include VAT and our invoices are payable to TERRES CUITES DES RAIRES S.A.S - 49430 Les Rairies - FRANCE. Our products are invoiced according to our price list and terms and conditions in force at the date of the order. They are modifiable without any notice.

Prices and indications mentioned in the catalogues, price lists and website are given for information only. RAIRES MONTRIEUX is bound by no commitment that may be made by its personnel unless confirmed in writing by the management team itself.

PAYMENTS

Whenever a new client opens an account, the total amount of the very first order is payable in advance before delivery. Regarding the following orders, the payment is due within 30 days of the end of the month.

When opening a new account, the client shall send their company registration certificate and bank details as well as the form provided for this purpose duly completed and signed. The payment method is the one mentioned in all our order acknowledgements.

Any delay of payment implying a breach of the aforementioned terms of payment shall automatically result in the enforceability of a penalty equal to the interest rate applied by the ECB on its latest refinancing operation plus ten percentage points at the due date of the applicable terms of payment.

GUARANTEE

Upon delivery, we guarantee that all standardized products comply with the NF EN standard and any other product complies with the specifications imposed by technical evaluations. Unless otherwise specified in our catalogue, all our products are guaranteed under legal conditions. Are excluded from the guarantee any fault that wasn't mentioned in reservations, any damage or defect caused by natural wear or by external factors or by the modification of a product. The benefit of the guarantee is dependent on appropriate storage, use, obligations, laying process and maintenance of our products according to good engineering practices.

Any complaint shall be sent in writing with photos within 48 hours upon receipt of goods. The latter shall not be taken into account once our products are used or laid. In case of delivery known as faulty or non-compliant, our responsibility is strictly limited to the replacement of the aforementioned goods to the exclusion of any charges and compensations. On no account, we shall be responsible for indirect damages (operating loss, late penalty...).

RETURN OF GOODS

Any return of products shall be subject to a formal prior consent from our sales department and within 30 days following the delivery. The returned products must be re-marketable and re-sent with the references of the delivery slip, the invoice and the return acknowledgement form. Return expenses and risks shall be at the Buyer's cost. The return shall be subject to a credit note based on the invoiced price after the deduction of 30% abatement.

RETENTION OF TITLE

By mutual agreement, the transfer of title is suspended until the principal and other costs have been paid in full.

DISPUTES

According to the terms hereinafter, no dispute or conflict shall entitle the client to withhold, interrupt or delay the payment or the acceptance of a bill. Should any dispute arise, the only competent jurisdiction shall be the courts where our head office is located. The applicable law is the French law.

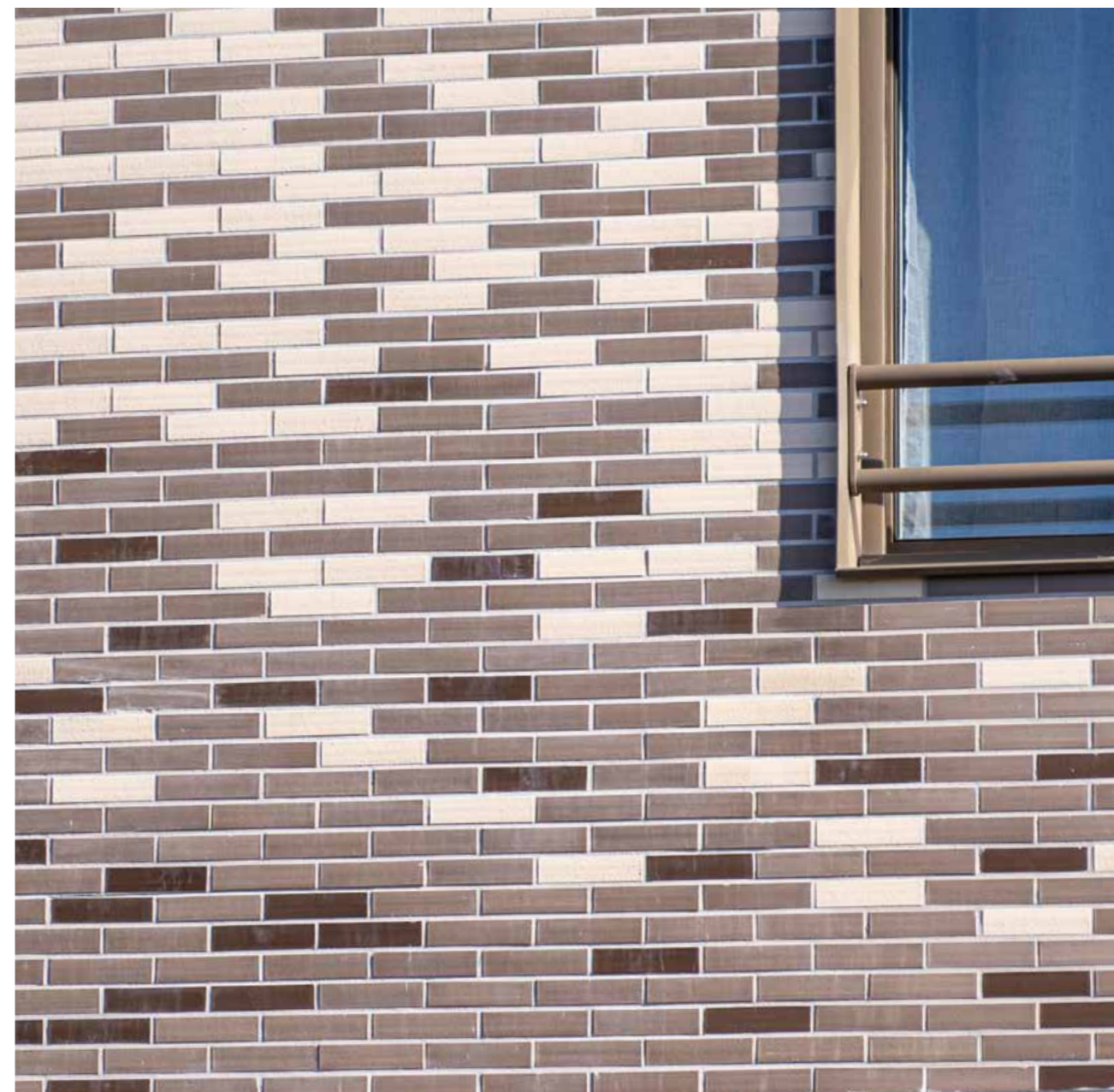

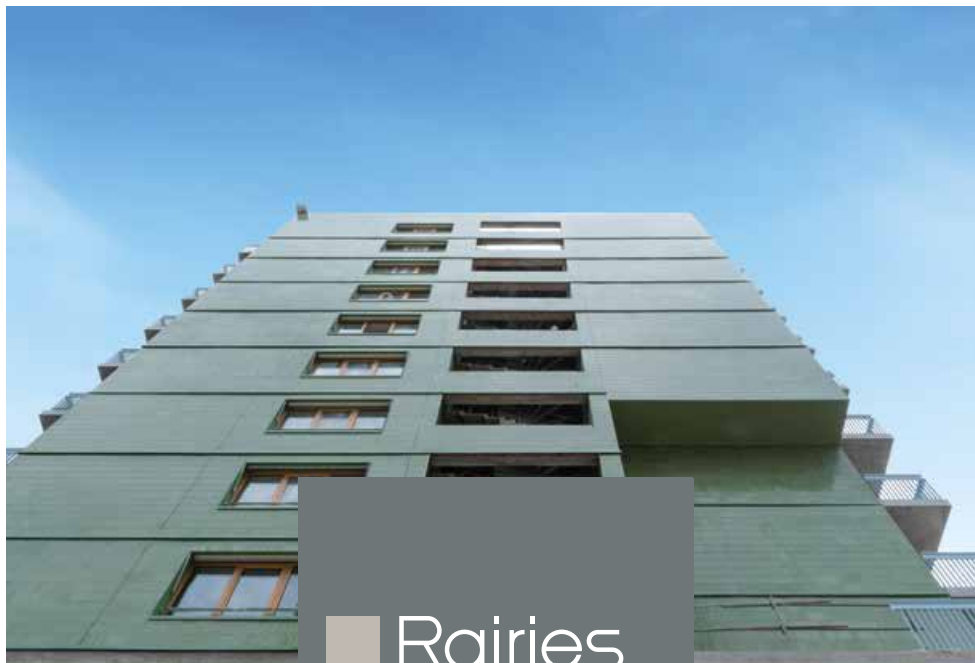

Rairies
Montrieux
TERRE D'ORIGINE

BÂTIR DURABLEMENT

1 rue des Fourneaux - 49430 Les Rairies
Tél : +33(0)2 41 21 15 20
Email : contact@montrieux.fr

113 avenue Daumesnil - 75012 Paris
Tél : +33(0)1 53 02 49 00
p.benaiche@montrieux.fr

www.rairies.com